

REVIEW ARTICLE

Calcium in Plants

PHILIP J. WHITE* and MARTIN R. BROADLEY

Horticulture Research International, Wellesbourne, Warwick CV35 9EF, UK

Received: 7 January 2003 Returned for revision: 26 March 2003 Accepted: 6 June 2003

Calcium is an essential plant nutrient. It is required for various structural roles in the cell wall and membranes, it is a counter-cation for inorganic and organic anions in the vacuole, and the cytosolic Ca^{2+} concentration ($[\text{Ca}^{2+}]_{\text{cyt}}$) is an obligate intracellular messenger coordinating responses to numerous developmental cues and environmental challenges. This article provides an overview of the nutritional requirements of different plants for Ca, and how this impacts on natural flora and the Ca content of crops. It also reviews recent work on (a) the mechanisms of Ca^{2+} transport across cellular membranes, (b) understanding the origins and specificity of $[\text{Ca}^{2+}]_{\text{cyt}}$ signals and (c) characterizing the cellular $[\text{Ca}^{2+}]_{\text{cyt}}$ -sensors (such as calmodulin, calcineurin B-like proteins and calcium-dependent protein kinases) that allow plant cells to respond appropriately to $[\text{Ca}^{2+}]_{\text{cyt}}$ signals.

© 2003 Annals of Botany Company

Key words: Arabidopsis, ATPase, calcium (Ca^{2+}), channel, cytosolic Ca^{2+} , ecology, $\text{H}^+/\text{Ca}^{2+}$ -antiport (CAX), kinase, phylogeny, plasma membrane, root, vacuole.

INTRODUCTION

Calcium is an essential plant nutrient. As the divalent cation (Ca^{2+}), it is required for structural roles in the cell wall and membranes, as a counter-cation for inorganic and organic anions in the vacuole, and as an intracellular messenger in the cytosol (Marschner, 1995). Calcium deficiency is rare in nature, but excessive Ca restricts plant communities on calcareous soils. Calcium is taken up by roots from the soil solution and delivered to the shoot via the xylem. It may traverse the root either through the cytoplasm of cells linked by plasmodesmata (the symplast) or through the spaces between cells (the apoplast). The relative contributions of the apoplastic and symplastic pathways to the delivery of Ca to the xylem are unknown (White, 2001). However, the movement of Ca through these pathways must be finely balanced to allow root cells to signal using cytosolic Ca^{2+} concentration ($[\text{Ca}^{2+}]_{\text{cyt}}$), control the rate of Ca delivery to the xylem, and prevent the accumulation of toxic cations in the shoot.

Calcium enters plant cells through Ca^{2+} -permeable ion channels in their plasma membranes (White, 2000). Since a high $[\text{Ca}^{2+}]_{\text{cyt}}$ is cytotoxic, a submicromolar $[\text{Ca}^{2+}]_{\text{cyt}}$ is maintained in unstimulated cells by Ca^{2+} -ATPases and $\text{H}^+/\text{Ca}^{2+}$ -antiporters (Sze *et al.*, 2000; Hirschi, 2001). These enzymes remove cytosolic Ca^{2+} to either the apoplast or the lumen of intracellular organelles, such as the vacuole or endoplasmic reticulum (ER). The rapid influx of Ca^{2+} through cation channels in the plasma membrane, tonoplast and/or ER generates $[\text{Ca}^{2+}]_{\text{cyt}}$ perturbations that initiate cellular responses to a diverse range of developmental cues and environmental challenges (White, 2000; Sanders *et al.*, 2002). Proteins that change conformation or catalytic activity upon binding Ca^{2+} , such as calmodulin (CaM),

calcineurin B-like proteins (CBLs) and Ca^{2+} -dependent protein kinases (CDPKs), allow the cellular perception and transduction of the $[\text{Ca}^{2+}]_{\text{cyt}}$ signal. These proteins are termed ' $[\text{Ca}^{2+}]_{\text{cyt}}$ sensors'. It is speculated that cellular responses to specific biotic and abiotic stimuli are encoded by distinct $[\text{Ca}^{2+}]_{\text{cyt}}$ perturbations and are transduced by particular $[\text{Ca}^{2+}]_{\text{cyt}}$ sensors. Much current work on Ca in plants is dedicated to understanding the nature and specificity of $[\text{Ca}^{2+}]_{\text{cyt}}$ signalling and response networks.

This article provides an overview of recent work on Ca in plants. First, it discusses the Ca requirements of different plant species, the mechanisms of Ca uptake and delivery to the xylem, and the impact of these on natural flora and the Ca content of crops. It then highlights the insights made possible by recent advances in electrophysiology, microscopy and plant molecular biology that have enabled researchers to characterize Ca^{2+} transporters in cellular membranes, begin to unravel the origins and specificity of $[\text{Ca}^{2+}]_{\text{cyt}}$ signals, and identify the $[\text{Ca}^{2+}]_{\text{cyt}}$ -sensors that allow plant cells to respond to $[\text{Ca}^{2+}]_{\text{cyt}}$ perturbations.

NUTRITION

The calcium requirements of plants

Plants growing with adequate Ca in their natural habitats have shoot Ca concentrations between 0.1 and 5 % d. wt (Marschner, 1995). These values reflect both Ca availability in the environment and the contrasting Ca requirements of different plant species. Calcium deficiency is rare in nature, but may occur on soils with low base saturation and/or high levels of acidic deposition (McLaughlin and Wimmer, 1999). By contrast, several costly Ca-deficiency disorders occur in horticulture (Fig. 1; Shear, 1975). These generally arise when sufficient Ca is momentarily unavailable to developing tissues. Deficiency symptoms are observed

* For correspondence. Fax 01789 470552, e-mail philip-j.white@hri.ac.uk

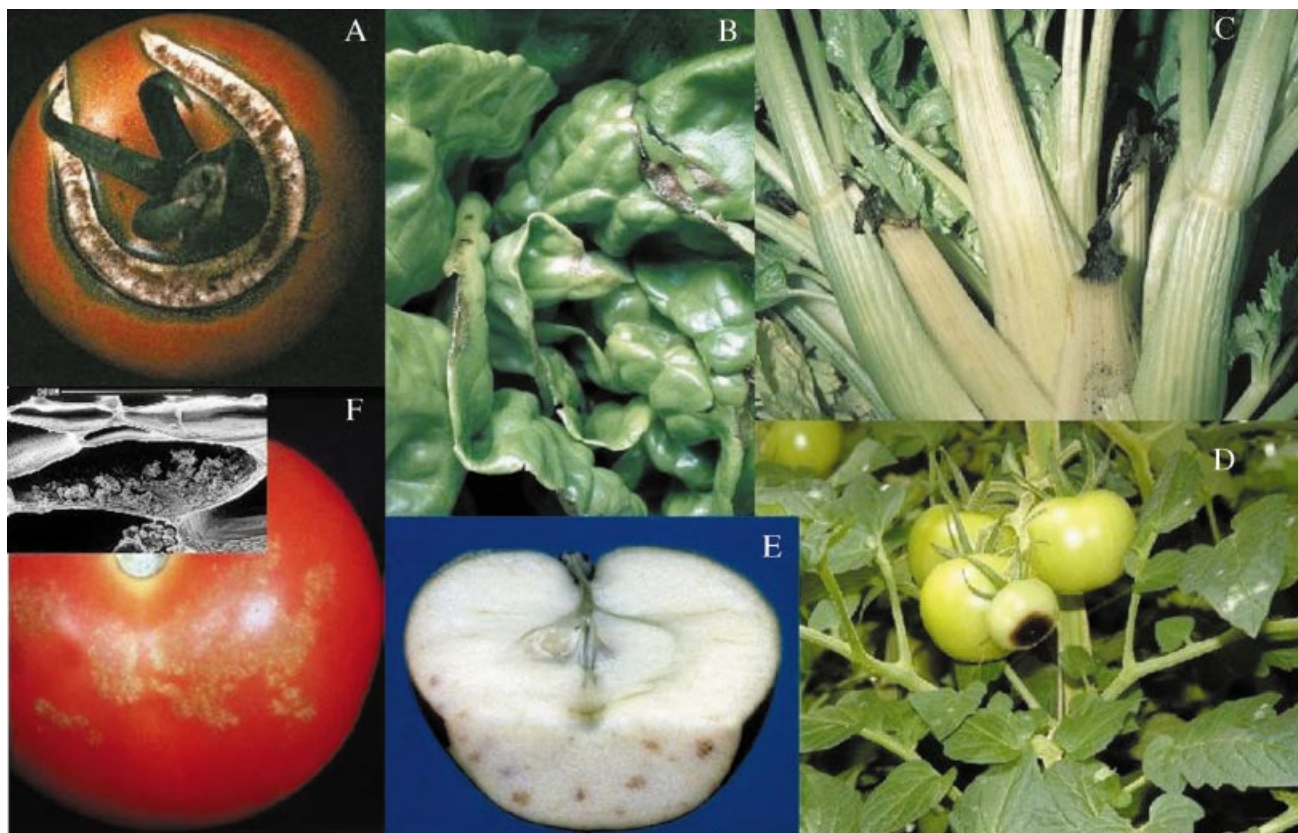

FIG. 1. Calcium disorders in horticultural crops: (a) cracking in tomato fruit; (b) tipburn in lettuce; (c) calcium deficiency in celery; (d) blossom end rot in immature tomato fruit; (e) bitter pit in apples; (f) gold spot in tomato fruit with calcium oxalate crystals (inset). Photographs (A–E) are from the HRI collection and (F) is courtesy of Lim Ho (HRI-Wellesbourne).

(a) in young expanding leaves, such as in ‘tipburn’ of leafy vegetables, (b) in enclosed tissues, such as in ‘brown heart’ of leafy vegetables or ‘black heart’ of celery, or (c) in tissues fed principally by the phloem rather than the xylem, such as in ‘blossom end rot’ of watermelon, pepper and tomato fruit, ‘bitter pit’ of apples and ‘empty pod’ in peanut. They occur because Ca cannot be mobilized from older tissues and redistributed via the phloem. This forces the developing tissues to rely on the immediate supply of Ca in the xylem, which is dependent on transpiration. Transpiration is low in young leaves, in enclosed tissues and in fruit. Other physiological disorders, such as ‘cracking’ in tomato, cherry and apple fruit, occur in tissues lacking sufficient Ca upon hypo-osmotic shock (following increased humidity or rainfall), presumably as a result of structural weaknesses in cell walls. When excessive Ca is present in the rhizosphere solution, plants may suffer Ca toxicity. This may prevent the germination of seeds and reduce plant growth rates (Fig. 2). In cultivated tomato, one symptom of excess calcium is the development of tiny yellowish flecks or ‘gold spot’ in the cell walls around the calyx and shoulders of the fruit (Fig. 1). These flecks are crystals of calcium oxalate and their abundance is increased by high humidity and high Ca fertilization (Bekreij *et al.*, 1992).

Ecologists have classified plant species into calcifuges, which occur on acid soils with low Ca, and calcicoles, which

occur on calcareous soils. The Ca concentrations in calcifuge and calcicole plants growing in their natural habitats differ markedly. However, it is the ability to tolerate excessive Al, Mn and Fe that largely determines the flora of acid soils, and an insensitivity to Fe- and P-deficiencies that determines the flora of calcareous soils (Lee, 1999). Nevertheless, calcifuges generally grow well at low Ca^{2+} concentrations in the rhizosphere ($[Ca^{2+}]_{ext}$) and respond little to increased $[Ca^{2+}]_{ext}$, which may even inhibit growth (Fig. 2). Conversely, the mechanisms that enable calcicole plants to maintain low $[Ca^{2+}]_{cyt}$ in their natural habitat are believed to restrict their growth at low $[Ca^{2+}]_{ext}$ by inducing Ca-deficiency (Fig. 2; Lee, 1999). This is consistent with the phenotype of plants overexpressing Ca^{2+} -transporters that remove Ca^{2+} from the cytoplasm to the vacuole which show Ca-deficiency symptoms at low $[Ca^{2+}]_{ext}$ (Hirschi, 2001). Hence, the optimal $[Ca^{2+}]_{ext}$ for a plant in hydroponics often approximates the $[Ca^{2+}]_{ext}$ of its natural habitat.

Distinct relationships between shoot Ca concentration ($[Ca]_{shoot}$) and $[Ca^{2+}]_{ext}$ have been attributed to contrasting Ca ‘physiotypes’ (Kinzel and Lechner, 1992). The ecology of different Ca physiotypes is thought to reflect their ability to utilize Ca as an osmoticum in primarily xerophytic, calcareous environments. One characteristic of calcicole plants, such as the Crassulaceae, Brassicaceae and Fabaceae, is a high soluble Ca concentration. In these

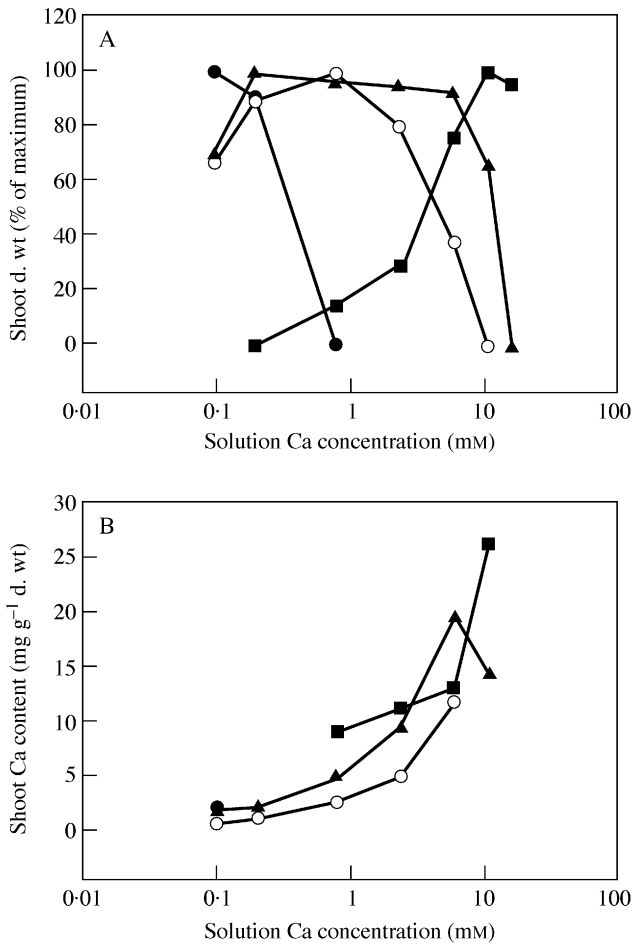

FIG. 2. The relationships between Ca concentration in the soil solution ($[Ca^{2+}]_{ext}$) and (A) shoot dry weight and (B) shoot Ca content of two calcifuge species *Juncus squarrosus* (filled circles) and *Nardus stricta* (filled triangles), the mineral-tolerant *Siegelingia decumbens* (open circles), and the calcicole species *Origanum vulgare* (filled squares). Plants were grown for approx. 4 weeks after germination in a quartz sand to which was added a complete mineral solution containing various concentrations of $CaCl_2$. Data are taken from Jefferies and Willis (1964), who observed (a) that *Juncus squarrosus* did not establish at $[Ca^{2+}]_{ext} \geq 0.8$ mM and (b) that *Origanum vulgare* showed symptoms of Ca deficiency and was unable to survive at $[Ca^{2+}]_{ext}$ less than about 0.8 mM.

plants, which are also termed ‘calcitrophs’ (Kinzel, 1982), Ca accumulation is stimulated greatly by increasing $[Ca^{2+}]_{ext}$. By contrast, calcifuges generally have a low soluble Ca concentration. They include the ‘potassium plants’, such as the Apiales and Asterales, which are characterized by high shoot K/Ca quotients, and the ‘oxalate plants’, which have high tissue oxalate concentrations. Plants that accumulate oxalate can be subdivided into species that contain soluble oxalate and those in which Ca-oxalate is precipitated. Interestingly, the uptake of Ca does not appear to increase with increasing $[Ca^{2+}]_{ext}$ in plants containing soluble oxalate, such as the Oxalidaceae (Kinzel and Lechner, 1992). In plants that precipitate Ca-oxalate such as the Caryophyllales families Caryophyllaceae, Chenopodiaceae and Polygonaceae, there is a proportional increase in both Ca and oxalate concentration with

increasing $[Ca^{2+}]_{ext}$ (Libert and Franceschi, 1987; Kinzel and Lechner, 1992).

Calcium uptake and movement to the shoot

Calcium is acquired from the soil solution by the root system and translocated to the shoot via the xylem. The Ca flux to the xylem is high, and a rate of $40 \text{ nmol Ca h}^{-1} \text{ g}^{-1} \text{ f. wt root}$ is not unreasonable in an actively growing plant (White, 1998). The delivery of Ca to the xylem is restricted to the extreme root tip and to regions in which lateral roots are being initiated (Clarkson, 1993; White, 2001). In these regions a contiguous, Casparian band between endodermal cells is absent or disrupted, and/or the endodermal cells surrounding the stele are unsuberized. The Casparian band restricts the apoplastic movement of solutes (Clarkson, 1984, 1993; White, 2001) and suberization prevents Ca^{2+} influx to endodermal cells (Moore *et al.*, 2002). These observations suggest that Ca might reach the xylem solely via the apoplast in regions where the Casparian band is absent or disrupted, or circumvent the Casparian band by entering the cytoplasm of unsuberized endodermal cells when the Casparian band is present (Clarkson, 1984, 1993; White 2001). These are referred to as the apoplastic and symplastic pathways, respectively.

Each pathway of Ca movement across the root confers distinct advantages and disadvantages. The apoplastic pathway allows Ca to be delivered to the xylem without impacting on the use of $[Ca^{2+}]_{cyt}$ for intracellular signalling (White, 1998). Intracellular signalling requires $[Ca^{2+}]_{cyt}$ to be maintained at submicromolar levels in the resting cell and to increase rapidly in response to developmental cues or environmental challenges. Since the Ca^{2+} fluxes required for $[Ca^{2+}]_{cyt}$ signalling are minute compared with those required for adequate nutrition, both these requirements for $[Ca^{2+}]_{cyt}$ signalling might be compromised by high nutritional Ca^{2+} fluxes through root cells (White, 2001). However, the Ca flux to the xylem through the apoplastic pathway is influenced markedly by transpiration, which could lead to vagaries in the amount of Ca supplied to the shoot and the development of Ca disorders (Marschner, 1995; McLaughlin and Wimmer, 1999). Furthermore, the apoplastic pathway is relatively non-selective between divalent cations (White, 2001; White *et al.*, 2002b), and its presence could result in the accumulation of toxic solutes in the shoot. By contrast, the symplastic pathway allows the plant to control the rate and selectivity of Ca transport to the shoot (Clarkson, 1993; White, 2001). It is thought that Ca^{2+} enters the cytoplasm of endodermal cells through Ca^{2+} -permeable channels on the cortical side of the Casparian band, and that Ca^{2+} is pumped from the symplast by the plasma membrane Ca^{2+} -ATPases or Ca^{2+}/H^+ -antiporters of cells within the stele. By regulating the expression and activity of these transporters, Ca could be delivered selectively to the xylem at a rate consistent with the requirements of the shoot.

Several lines of evidence suggest that both apoplastic and symplastic pathways contribute to Ca delivery to the xylem. First, since Ca is delivered to the xylem in regions of the root where the Casparian band is fully developed and

apoplastic Ca transport is restricted, some Ca might bypass the Casparian band through the cytoplasm of endodermal cells (Clarkson, 1984, 1993; White, 2001). Secondly, although Ca^{2+} channels and Ca^{2+} -ATPases are present and thermodynamically capable of catalysing Ca^{2+} influx and efflux across the plasma membrane of root endodermal cells, it has been calculated that there is insufficient ATP to power (Flowers and Yeo, 1992) and insufficient proteins to catalyse (White, 1998, 2001) the observed Ca^{2+} fluxes solely through the symplast. Thirdly, if Ca reached the xylem solely by a symplastic pathway, its accumulation in the shoot would be expected to show the hallmarks of protein-catalysed transport, which it does not. For example, both Ca^{2+} channels in the plasma membrane of root cells and Ca^{2+} -ATPases discriminate between divalent cations, but there seems to be no discrimination between Ca^{2+} , Ba^{2+} and Sr^{2+} in their transport to the shoot (White, 2001). Furthermore, there seems to be no competition, or interactions, between Ca^{2+} , Ba^{2+} and Sr^{2+} during their transport to the shoot, and the accumulation of divalent cations in the shoot is often linearly related to their concentrations in the rhizosphere solution (White, 2001). Although the relative contributions of the apoplastic and symplastic pathways to the delivery of Ca to the xylem are unknown, it is likely that a functional separation of apoplastic Ca^{2+} fluxes (for transfer to the shoot) and symplastic Ca^{2+} fluxes (for cell signalling) would enable the root to fulfil the demand of the shoot for Ca without compromising intracellular $[\text{Ca}^{2+}]_{\text{cyt}}$ signals.

The Ca concentration in xylem sap ($[\text{Ca}]_{\text{xylem}}$) is influenced greatly by $[\text{Ca}^{2+}]_{\text{ext}}$ and $[\text{Ca}]_{\text{xylem}}$ between 300 μM and 16.5 mM has been reported (White *et al.*, 1992; De Silva *et al.*, 1998). The relative proportion of Ca^{2+} to total Ca also varies, with organic acids, such as malate and citrate, chelating Ca^{2+} in the xylem sap (Marschner, 1995). When abundant Ca is present in the xylem sap, there is a close relationship between Ca distribution to the shoot and transpiration. Within the leaf, Ca follows the apoplastic route of the transpiration stream and accumulates in either the mesophyll cells, trichomes or epidermal cells adjacent to guard cells, depending on the plant species (Karley *et al.*, 2000). Both the $[\text{Ca}^{2+}]_{\text{cyt}}$ in guard cells and the closing of stomata in detached epidermal strips are sensitive to apoplastic Ca^{2+} concentrations within the range of $[\text{Ca}^{2+}]_{\text{xylem}}$ (McAinsh *et al.*, 1995) and the ability of some calcicole species, such as *Leontodon hispidus* and *Centaurea scabiosa*, to tolerate high $[\text{Ca}^{2+}]_{\text{ext}}$ may be related to their ability to accumulate Ca in their trichomes (De Silva *et al.*, 1996, 1998).

The phylogeny of shoot calcium concentration

When grown under identical conditions, the $[\text{Ca}]_{\text{shoot}}$ of different plant species differs markedly (Figs 2 and 3 and Table 1; Broadley *et al.*, 2003a). A large proportion of this variation can be attributed to the phylogenetic division between eudicots and monocots (Thompson *et al.*, 1997; Broadley *et al.*, 2003a). Eudicots generally have a higher $[\text{Ca}]_{\text{shoot}}$ than monocots. Within the eudicots, orders within both the rosid (Cucurbitales, Rosales, Malvales and Brassicales) and asterid (Apiales, Asterales, Lamiales and

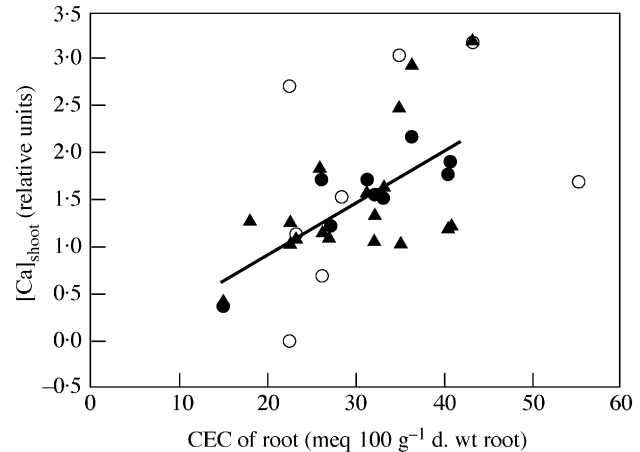

FIG. 3. The relationships between root CEC, derived from a literature survey, and shoot calcium concentration, derived from both literature and experimental data, for angiosperm orders (Table 1). Circles represent shoot Ca content data from a literature survey. Filled circles and linear regression represent orders with $n \geq 3$ species sampled. Triangles represent shoot Ca content estimated in a phylogenetically balanced experiment.

Solanales) clades have the highest $[\text{Ca}]_{\text{shoot}}$. Within the monocots, $[\text{Ca}]_{\text{shoot}}$ is higher in the non-commelinoid orders (e.g. Asparagales) than in the commelinoid orders (e.g. Poales). Phylogenetic differences in $[\text{Ca}]_{\text{shoot}}$ have not been resolved at lower taxonomic levels, but it is noteworthy that distinct Ca physiotypes ('calcitrophes', 'potassium plants' and 'oxalate plants') occur in particular plant families (Kinzel, 1982) and that traits such as the prevalence, shape and tissue distributions of Ca oxalate crystals, are used as taxonomic characters (e.g. Franceschi and Horner, 1980; Kuo-Huang *et al.*, 1994; Wu and Kuo-Huang, 1997; Prychid and Rudall, 1999; Caddick *et al.*, 2002).

Although the Ca physiotype of a plant determines its ability to accumulate Ca in the shoot (Kinzel and Lechner, 1992; Broadley *et al.*, 2003a), genotypic differences in the activities of Ca^{2+} transporters in root cell membranes (Hirschi, 2001; White *et al.*, 2002a) and/or in the relative contributions of symplastic and apoplastic pathways to the delivery of Ca to the xylem (White, 2001) will contribute much to phylogenetic variation in $[\text{Ca}]_{\text{shoot}}$. Historically, $[\text{Ca}]_{\text{shoot}}$ has been correlated with the cation exchange capacity (CEC) of plant roots (Fig. 3). The CEC is located in the root apoplast, and is attributed to the free carboxyl groups of galacturonic acids of cell wall pectins in the middle lamella (Haynes, 1980; Sattelmacher, 2001). If the pectin contents of shoot and root cell walls are similar, it is unsurprising that the phylogenetic variation in CEC in monocot roots parallels that in pectin content of shoot cell walls (Jarvis *et al.*, 1988). The pectin contents of shoot cell walls are low in the Cyperaceae, Poaceae, Juncaceae and Restionaceae families (all assigned to the Poales) and intermediate in the commelinoid monocot families Commelinaceae (Commelinales), Bromeliaceae (unassigned to order) and Typhaceae (Poales) and in the non-commelinoid Pandanaceae (Pandanales) family. The pectin content of shoot cell walls is similar to that of dicots in the

TABLE 1. The mean relative shoot calcium concentration of angiosperm orders derived from both a literature survey and a phylogenetically balanced experiment, and their mean relative root cation exchange capacity (CEC)

Order	Literature		Literature		Experiment	
	Root CEC (meq 100 g ⁻¹ d. wt root)	No. spp.	Relative shoot [Ca]	No. spp.	Relative shoot [Ca]	No. spp.
Apiales	40-67	3	1.90	5	1.21	4
Aquifoliales	27-28	1	—	—	—	—
Asparagales	27-08	6	1.22	4	1.10	13
Asterales	40-34	12	1.78	11	1.19	15
Brassicales	36-39	7	2.19	15	2.96	3
Caryophyllales	32-12	12	1.57	17	1.07	7
Cucurbitales	43-35	4	3.19	2	3.21	1
Dipsacales	35-01	1	—	—	1.04	2
Ericales	22-54	2	-0.01	1	1.04	1
Fabales	33-03	23	1.53	78	1.66	9
Gentianales	32-21	1	—	—	1.36	4
Geraniales	28-41	4	1.53	2	—	—
Lamiales	25-96	2	1.72	5	1.84	7
Laurales	-2.07	1	—	—	—	—
Liliales	24-06	2	—	—	—	—
Malpighiales	23-18	1	1.12	2	1.07	5
Malvales	34-91	1	3.04	2	2.50	3
Myrtales	26-21	1	0.70	1	1.13	6
Poales	14-94	50	0.37	48	0.43	18
Ranunculales	55-42	4	1.69	2	—	—
Rosales	22-54	4	2.73	1	1.25	3
Sapidales	17-98	6	—	—	1.29	4
Solanales	31-22	4	1.73	8	1.60	4
Vitaceae	15-67	2	—	—	—	—

Data for shoot Ca concentration were taken from Broadley *et al.* (2003a) and for root CEC from the comparative studies cited by Asher and Ozanne (1961), Heintz (1961), Crooke and Knight (1962), Fréjat *et al.* (1967), Snaydon and Bradshaw (1969) or Wacquant (1977).

All literature data sets were subjected to a residual maximum likelihood (REML) analysis, using a procedure described previously (Broadley *et al.*, 2001). This procedure adjusted for differences in between-study means to generate mean relative shoot Ca concentration (206 plant species in 18 orders from 244 studies) and mean relative root CEC (154 plant species from 93 studies).

Data are expressed as order means from *n* species sampled.

commelinoid monocot families Musaceae (Zingiberales) and Sparganiaceae (Poales) and in the non-commelinoid monocot families Velloziaceae (Pandanales), Alliaceae Amaryllidaceae, Asphodelaceae, Iridaceae, Orchidaceae (all Asparagales), Alismataceae, Araceae, Juncaginaceae, Potamogetonaceae, Zosteraceae (all Alismatales) and Liliaceae (Liliales).

In regions of the root where the Ca flux to the xylem is apoplastic, CEC may exert a direct effect on the transport of Ca²⁺ to the shoot. However, several reviews have asserted that there is no direct connection between the capacity of roots to bind cations in the free space and their active (energy-dependent) accumulation (e.g. Haynes, 1980). Nevertheless, fixed negative charges, and charge screening, can influence both the absolute and relative concentrations of cations in the apoplast, especially at low ionic activities. Thus, root CEC could determine shoot cation content indirectly by affecting the rate and selectivity of cation uptake into the symplast in addition to cation transport through the apoplast (Asher and Ozanne, 1961; Wacquant, 1977). The effects of CEC on cation transport may have ecological implications. It has been suggested that, in solutions of low ionic strength, plants with higher root CEC

compete for divalent cations more effectively, whereas plants with lower root CEC compete for monovalent cations more effectively (Smith and Wallace, 1956; Asher and Ozanne, 1961).

Quantifying the phylogenetic impact on [Ca]_{shoot} has several uses. First, since [Ca]_{shoot} correlates with ecological traits (Kinzel, 1982; Thompson *et al.*, 1997; Grime, 2001), predictions of the responses of plant communities to environmental change can be improved using this information. Secondly, knowledge of phylogenetic variation in [Ca]_{shoot} can be used to predict the movement of Ca (and chemically similar elements such as Sr, Mg and Ba; White, 2001; Broadley *et al.*, 2003b) from soils to the shoots of plant species whose transfer coefficients are unknown and, thereby, improve nutrient and contaminant cycling models (Broadley *et al.*, 2001). Thirdly, appreciation of phylogenetic influences on [Ca]_{shoot} can improve the delivery of Ca to the human diet. Unsurprisingly, Ca-deficiency disorders have been observed in populations whose dietary habits have changed from bean-rich to rice-rich sources of food (Graham *et al.*, 2001). Phylogenetic information can help identify crops that are either predisposed to higher [Ca]_{shoot} or offer genetic potential for breeding.

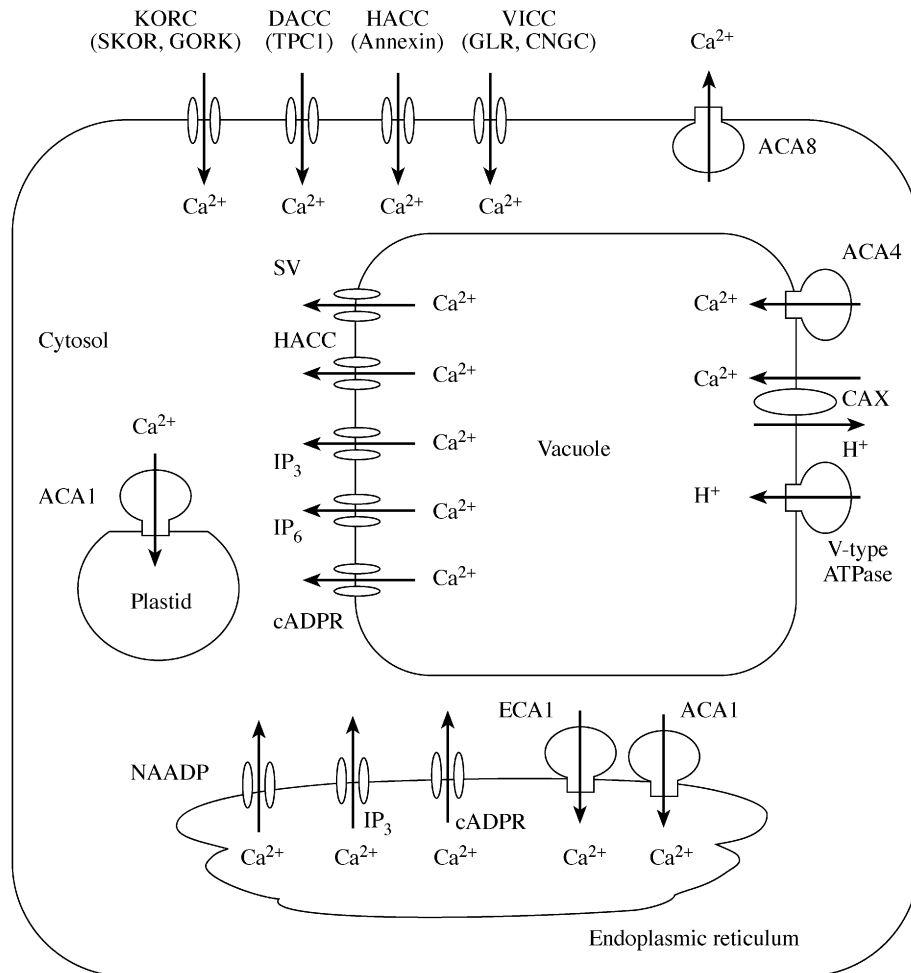

FIG. 4. Cartoon illustrating the subcellular location of Ca^{2+} transporters in *Arabidopsis thaliana* based on Sze *et al.* (2000), Sanders *et al.* (2002) and White *et al.* (2002). In the plasma membrane there are hyperpolarization-activated Ca^{2+} channels (HACC, possibly encoded by annexin genes), depolarization-activated Ca^{2+} channels (DACC, one of which may be encoded by *TPC1*), Ca^{2+} -permeable outward rectifying K^{+} channels (KORC, encoded by *SKOR* and *GORK*), voltage-insensitive cation channels (VICC, probably encoded by the *CNGC* and *GLR* genes) and Ca^{2+} -ATPases (one of which is ACA8). Biochemical and electrophysiological evidence indicates that IP_3 -receptors, IP_6 -receptors, cADPR-activated (ryanodine)-receptors and two types of voltage-gated Ca^{2+} channels (the depolarization-activated SV channels and the hyperpolarization-activated Ca^{2+} channels) are present in the tonoplast together with Ca^{2+} -ATPases (including ACA4) and $\text{H}^{+}/\text{Ca}^{2+}$ -antiporters encoded by the *CAX* genes. There is also biochemical and electrophysiological evidence for the presence of NAADP-receptors, IP_3 -receptors, cADPR-activated (ryanodine)-receptors and depolarization-activated Ca^{2+} channels in the endoplasmic reticulum (ER), together with Ca^{2+} -ATPases (including ECA1 and ACA2). The Ca^{2+} -ATPase ACA1 is located in the plastid inner membrane.

CALCIUM TRANSPORTERS IN CELLULAR MEMBRANES

*Ca*²⁺ efflux from the cytosol: *Ca*²⁺-ATPases and *H*⁺/*Ca*²⁺-antiporters

The removal of Ca^{2+} from the cytosol against its electrochemical gradient to either the apoplast or to intracellular organelles requires energized, 'active' transport. This is catalysed by Ca^{2+} -ATPases and $\text{H}^{+}/\text{Ca}^{2+}$ -antiporters (Fig. 4). By removing Ca^{2+} from the cytosol these enzymes perform several important functions (Sze *et al.*, 2000; Hirschi, 2001): (1) they maintain a low $[\text{Ca}^{2+}]_{\text{cyt}}$ in the resting (unstimulated) cell appropriate for cytoplasmic metabolism; (2) they restore $[\text{Ca}^{2+}]_{\text{cyt}}$ to resting levels following a $[\text{Ca}^{2+}]_{\text{cyt}}$ perturbation, thereby influencing the magnitude,

kinetics and subcellular location of $[\text{Ca}^{2+}]_{\text{cyt}}$ signals; (3) they replenish intracellular and extracellular Ca^{2+} stores for subsequent $[\text{Ca}^{2+}]_{\text{cyt}}$ signals and permit the generation of local $[\text{Ca}^{2+}]_{\text{cyt}}$ oscillations through their interplay with Ca^{2+} channels (Klüsener *et al.*, 1995; Harper, 2001); (4) they provide Ca^{2+} in the ER for the secretory system to function (Blatt, 2000b; Ritchie *et al.*, 2002); (5) they remove divalent cations, such as Mg^{2+} , Mn^{2+} , Ni^{2+} or Zn^{2+} , from the cytosol, to support the specialized biochemistry of particular organelles and to prevent mineral toxicities (Hirschi, 2001; Wu *et al.*, 2002). The relative importance of Ca^{2+} -ATPases and $\text{H}^{+}/\text{Ca}^{2+}$ -antiporters in each of these functions is unknown. Hirschi (2001) suggested that the Ca^{2+} -ATPases, which have high affinity ($K_m = 1\text{--}10\ \mu\text{M}$; Evans and Williams, 1998) but low capacity for Ca^{2+} transport, are

responsible for maintaining $[Ca^{2+}]_{cyt}$ homeostasis in the resting cell, whereas the H^+/Ca^{2+} -antiporters, which have lower affinities ($K_m = 10\text{--}15\ \mu M$) but high capacities for Ca^{2+} transport, are likely to remove Ca^{2+} from the cytosol during $[Ca^{2+}]_{cyt}$ signals and thereby modulate $[Ca^{2+}]_{cyt}$ perturbations. Consistent with this hypothesis is the observation that an H^+/Ca^{2+} -antiporter, but not the vacuolar Ca^{2+} -ATPase, resets $[Ca^{2+}]_{cyt}$ in yeast following hypertonic shock (Denis and Cyert, 2002). However, the *Arabidopsis detiolated 3 (det3)* mutant, which has reduced tonoplast H^+ -ATPase and (presumably) H^+/Ca^{2+} -antiporter activity, has a constitutively high $[Ca^{2+}]_{cyt}$ (Allen *et al.*, 2000), suggesting that H^+/Ca^{2+} -antiporters contribute to $[Ca^{2+}]_{cyt}$ homeostasis, and plants poisoned by the V-type H^+ -ATPase inhibitor bafilomycin show greater $[Ca^{2+}]_{cyt}$ elevations in response to hypo-osmotic shock (Takahashi *et al.*, 1997).

Plant Ca^{2+} ATPases belong to one of two major families (Evans and Williams, 1998; Geisler *et al.*, 2000; Sze *et al.*, 2000; Axelsen and Palmgren, 2001; Garciadeblas *et al.*, 2001). The first family (the P-type ATPase IIA family) lacks an N-terminal autoregulatory domain. Four members of this family have been identified in the arabidopsis genome (termed AtECAs 1 to 4 by Axelsen and Palmgren, 2001). They are likely to be present in the plasma membrane, tonoplast and the ER/Golgi apparatus. In tomato, two transcripts of a type IIA Ca^{2+} -ATPase (*LeLCA1*) were observed in phosphate-starved roots that correlated with two distinct protein isoforms (120 and 116 kDa) located in the plasma membrane and tonoplast of root cells, respectively (Navarro-Avino *et al.*, 1999). The second family of plant Ca^{2+} ATPases (the P-type ATPase IIB family) is characterized by an autoinhibitory N-terminal domain that contains a binding site for Ca-CaM plus a serine-residue phosphorylation site. Their catalytic activity can be modulated by $[Ca^{2+}]_{cyt}$ either through activation upon binding CaM or by inhibition following phosphorylation by Ca^{2+} -dependent protein kinases (CDPK; Hwang *et al.*, 2000). Since CaM binding-sites are generally quite diverse, each type-IIB Ca^{2+} -ATPase may have a different affinity for CaM or may bind a different CaM isoform. Ten members of the type-IIB Ca^{2+} -ATPase family have been identified in the arabidopsis genome (termed AtACAs 1, 2 and 4 and AtACAs 7 to 13 by Axelsen and Palmgren, 2001). These reside on various cellular membranes including the plasma membrane (AtACA8), the tonoplast (AtACA4), ER (AtACA2) and the plastid inner membrane (AtACA1). Several explanations for the abundance of Ca^{2+} -ATPase isoforms, and also the presence of several isoforms on the same cellular membrane (such as AtECA1 and AtACA2 in the root ER) have been proposed (Geisler *et al.*, 2000; Sze *et al.*, 2000; Axelsen and Palmgren, 2001). Such explanations typically suggest that individual isoforms are functionally distinct and specialized to specific cellular processes requiring distinct spatial or temporal expression. They also imply a requirement for CaM-independent and CaM-dependent regulation of Ca^{2+} -ATPase activities in the modulation of $[Ca^{2+}]_{cyt}$ perturbations during cell signalling. Multiple Ca^{2+} -ATPase genes are required to effect this because alternative splicing events are rare in plants. Intriguingly, the expression of many Ca^{2+} -ATPases is increased upon exposure to

high salinity or high $[Ca^{2+}]_{ext}$, and some Ca^{2+} -ATPase genes are expressed only under stress conditions (Geisler *et al.*, 2000; Garciadeblas *et al.*, 2001). This may reflect a role in maintaining $[Ca^{2+}]_{cyt}$ homeostasis or in reducing Na^+ influx to the cytosol in saline environments.

The H^+/Ca^{2+} -antiporters present in the plasma membrane and tonoplast have been characterized biochemically (Evans and Williams, 1998; Sanders *et al.*, 2002). These have a lower affinity for Ca^{2+} than the Ca^{2+} -ATPases, and may also transport Mg^{2+} . The stoichiometry of the dominant H^+/Ca^{2+} -antiporter in the tonoplast is apparently $3H^+/1Ca^{2+}$ (Blackford *et al.*, 1990). Eleven genes encoding putative H^+/Ca^{2+} -antiporters (*AtCAX*) have been identified in the genome of *Arabidopsis thaliana* (Hirschi, 2001; Mäser *et al.*, 2001). The transporters AtCAX1, AtCAX2 and AtCAX4 are located at the tonoplast (Hirschi, 2001; N. Cheng *et al.*, 2002, 2003). The AtCAX1 antiporter exhibits both a high affinity and high specificity for Ca^{2+} . By contrast, the AtCAX2 transporter is a high-affinity, high capacity H^+ /heavy metal cation antiporter. The cation specificity of other AtCAXs is unknown, but may reside in a specific stretch of nine amino acids termed the ' Ca^{2+} domain' (Shigaki *et al.*, 2002). The increased transport capacity of truncated versions of AtCAX1, AtCAX3 and AtCAX4, and their relative inhibition by synthetic peptides corresponding to these deletions, suggest that they are subject to autoinhibition by their N-termini in an isoform-specific manner (N. Cheng *et al.*, 2002; Pittman *et al.*, 2002a, b). How, and whether, this regulatory mechanism operates *in vivo* has yet to be revealed.

The AtCAXs have homologues in other plant species and their physiological roles have been investigated using transgenic plants (Hirschi, 2001). Transgenic tobacco overexpressing *AtCAX1* exhibits Ca-deficiency disorders, such as tipburn, metal-hypersensitivity and susceptibility to chilling, that can be reversed by increasing Ca supply. Since these plants have increased $[Ca]_{shoot}$, Hirschi (2001) speculated that such phenotypes resulted from depleted $[Ca^{2+}]_{cyt}$, suggesting that the principal role of AtCAX1 was to maintain $[Ca^{2+}]_{cyt}$ homeostasis by removing excess cytosolic Ca^{2+} to the vacuole, and noted that the expression of *AtCAX1* and *AtCAX3* (but not *AtCAX2* or *AtCAX4*) was increased by raising Ca supply (Shigaki and Hirschi, 2000; Hirschi, 2001; N. Cheng *et al.*, 2002).

Ca²⁺ influx to the cytosol: calcium channels

Calcium-permeable channels have been found in all plant membranes (Fig. 4). They have been classified on the basis of their voltage-dependence into depolarization-activated (DACC), hyperpolarization-activated (HACC) and voltage-independent (VICC) cation channels (White, 2000; Miedema *et al.*, 2001; Sanders *et al.*, 2002). The presence of diverse classes of Ca^{2+} -permeable channels in a particular membrane is thought to enable physiological flexibility.

The principal roles of Ca^{2+} -permeable channels in the plasma membrane appear to be in cell signalling, but they may also contribute to nutritional Ca^{2+} fluxes in particular cell types (White, 1998, 2000; Miedema *et al.*, 2001). Several types of DACCs have been observed in the plasma

membrane of plant cells (White, 1998, 2000). Although each has distinct pharmacological and electrophysiological properties, all are permeable to both monovalent and divalent cations. They may therefore contribute to the uptake of essential or toxic cations in addition to Ca^{2+} . Most DACCs activate significantly at voltages more positive than about -150 to -100 mV under physiological conditions (White, 1998). The dominant DACCs in protoplasts from arabidopsis tissues and carrot suspension cells appear to be controlled by cytoskeletal interactions and stabilized by the disruption of microtubules (Thion *et al.*, 1996, 1998). It is argued that DACCs transduce general stress-related signals since plasma membrane depolarization is common to many stimuli, occurs by many diverse mechanisms, and is likely to increase $[\text{Ca}^{2+}]_{\text{cyt}}$ throughout the cell periphery (White, 1998, 2000). However, specific roles for DACCs acting in tandem with cytoskeletal rearrangements have been proposed in the acclimation of chilling-resistant plants to low temperatures (Mazars *et al.*, 1997; White, 1998; Xiong *et al.*, 2002) and in the interactions of plants with microbes (White *et al.*, 2002a). The outward-rectifying K^+ channels (KORCs) found in the plasma membrane of plant cells are also Ca^{2+} -permeable DACCs (White *et al.*, 2002a). These channels activate significantly at voltages more positive than about -50 mV under most physiological conditions and catalyse a large K^+ efflux simultaneously with a small Ca^{2+} influx (White, 1997; Gaymard *et al.*, 1998; De Boer, 1999; Roberts and Snowman, 2000). The Ca^{2+} influx through KORCs might increase $[\text{Ca}^{2+}]_{\text{cyt}}$ to coordinate ion transport, metabolism and gene expression. An elaborate model of how negative feedback through $[\text{Ca}^{2+}]_{\text{cyt}}$ might control the loading of K^+ into the root xylem by KORCs has been proposed by De Boer (1999).

Patch-clamp electrophysiological techniques have identified HACCs in root cells (Kiegle *et al.*, 2000a; Véry and Davies, 2000; Foreman *et al.*, 2003), onion epidermal cells (Pickard and Ding, 1993), suspension-cultured tomato cells (Blumwald *et al.*, 1998), leaf mesophyll cells (Stoelzle *et al.*, 2003) and stomatal guard cells (Hamilton *et al.*, 2000, 2001; Pei *et al.*, 2000; Murata *et al.*, 2001; Perfus-Barbeoch *et al.*, 2002). These channels are permeable to many divalent cations including Ba^{2+} , Ca^{2+} , Mg^{2+} , Mn^{2+} , Cd^{2+} and Zn^{2+} . They activate at voltages more negative than about -100 to -150 mV at physiological $[\text{Ca}^{2+}]_{\text{cyt}}$, but increasing $[\text{Ca}^{2+}]_{\text{cyt}}$ shifts their activation potential to more positive voltages in root hairs (Véry and Davies, 2000) or more negative voltages in guard cells (Hamilton *et al.*, 2000). At the apex of root hairs and pollen tubes, and in cells of the root elongation zone, the regulation of HACCs by $[\text{Ca}^{2+}]_{\text{cyt}}$ may provide a positive feedback system to generate and maintain the elevated $[\text{Ca}^{2+}]_{\text{cyt}}$ required for cell expansion (White, 1998, 2000; Véry and Davies, 2000; Miedema *et al.*, 2001; Demidchik *et al.*, 2002a). Mechanosensitive HACCs may orchestrate the changes in morphology induced by gravity, touch or flexure in a similar manner (Pickard and Ding, 1993; Bibikova *et al.*, 1999). Reactive oxygen species also increase the activity of HACCs in root hairs (Foreman *et al.*, 2003), guard cells (Pei *et al.*, 2000; Murata *et al.*, 2001; Klüsener *et al.*, 2002; Köhler *et al.*, 2003) and suspension-cultured cells (Lecourieux *et al.*, 2002) through the activity

of NADPH oxidases. Oxidative bursts have been correlated with elevated $[\text{Ca}^{2+}]_{\text{cyt}}$, the initiation of $[\text{Ca}^{2+}]_{\text{cyt}}$ waves, elongation growth, altered gene expression and the induction of antimicrobial activities. Elicitor-activated HACCs, such as those activated by a heterotrimeric G-protein/protein kinase cascade in suspension-cultured tomato cells, are thought to raise $[\text{Ca}^{2+}]_{\text{cyt}}$ to initiate cellular responses to pathogens (Blumwald *et al.*, 1998). In guard cells, HACCs have a central role in closing stomata during water stress. Increasing ABA concentration shifts the activation potential of HACCs to more positive voltages, thereby promoting their opening, and the subsequent entry of Ca^{2+} not only depolarizes the plasma membrane but also initiates the $[\text{Ca}^{2+}]_{\text{cyt}}$ -dependent events, including $[\text{Ca}^{2+}]_{\text{cyt}}$ -dependent Ca^{2+} release (CICR) from intracellular stores, that lead to stomatal closure (Blatt, 2000a, b; White, 2000; Murata *et al.*, 2001; Schroeder *et al.*, 2001; Köhler and Blatt, 2002).

Many distinct VICCs are present in the plasma membrane of plant cells, which differ in cation selectivity, voltage-dependence and pharmacology (White *et al.*, 2002a; Demidchik *et al.*, 2002b). Nevertheless, all VICCs appear to be permeable to both monovalent and divalent cations (Davenport and Tester, 2000; Demidchik and Tester, 2002; Demidchik *et al.*, 2002a, b) and are likely to provide a weakly voltage-dependent Ca^{2+} influx to cells under physiological ionic conditions (White and Davenport, 2002; Demidchik *et al.*, 2002a). It has been suggested that Ca^{2+} influx through VICCs, which are open at physiological voltages and are generally insensitive to cytoplasmic modulators, is required to balance the perpetual Ca^{2+} efflux through Ca^{2+} -ATPases and $\text{H}^+/\text{Ca}^{2+}$ -antiporters to maintain $[\text{Ca}^{2+}]_{\text{cyt}}$ homeostasis in an unstimulated plant cell (White and Davenport, 2002). This hypothesis is supported both by the pharmacology of Ca^{2+} influx to plant root cells and the linear dependence of their $[\text{Ca}^{2+}]_{\text{cyt}}$ on cell membrane potential (Demidchik *et al.*, 2002a). Furthermore, VICCs appear to be the only Ca^{2+} -permeable channels open at the resting potential of most plant cells.

There has been some recent speculation on the identity of genes encoding Ca^{2+} -permeable channels in the plasma membranes of plant cells (Demidchik *et al.*, 2002b; Véry and Sentenac, 2002; White *et al.*, 2002a). It has been suggested (a) that homologues of the arabidopsis *AtTPC1* gene (Furuichi *et al.*, 2001) encode DACCs regulated by $[\text{Ca}^{2+}]_{\text{cyt}}$, (b) that homologues of the arabidopsis *AtSKOR* (Gaymard *et al.*, 1998) and *AtGORK* (Ache *et al.*, 2000) genes encode KORCs, (c) that the annexin genes encode HACCs and (d) that genes from the cyclic-nucleotide gated channel (CNGC) and glutamate receptor (GLR) families encode VICCs. Since CNGCs have a binding site for CaM within a C-terminus binding site for cyclic nucleotide monophosphates, CNGC could impose a 'coincidence hierarchy' for $[\text{Ca}^{2+}]_{\text{cyt}}$ signalling by integrating the response to two different signalling cascades acting simultaneously. The low-affinity cation transporter in the plasma membrane of wheat root cells (TaLCT1) could also facilitate Ca^{2+} uptake into plant cells (Clemens *et al.*, 1998), but it is not known whether this protein forms an ion channel.

Several Ca^{2+} -permeable channels co-reside in the tonoplast (Allen and Sanders, 1997; White, 2000; Sanders *et al.*, 2002). At least three types of pharmacologically distinct depolarization-activated Ca^{2+} -permeable channels have been observed, of which the SV type is the most common. The SV channels are permeable to monovalent and divalent cations and catalyse a small Ca^{2+} influx to the cytoplasm under physiological conditions (Pottosin *et al.*, 1997, 2001; White, 2000). They are regulated by many effectors, suggesting that they could be pivotal in effecting the coincidence control of $[\text{Ca}^{2+}]_{\text{cyt}}$ signalling (Sanders *et al.*, 1999, 2002; White, 2000). Increasing $[\text{Ca}^{2+}]_{\text{cyt}}$ or decreasing vacuolar Ca^{2+} concentration ($[\text{Ca}^{2+}]_{\text{vac}}$) promotes their opening at physiological trans-tonoplast voltages. Their response to $[\text{Ca}^{2+}]_{\text{cyt}}$ is sensitized both by CaM and by cytosolic Mg^{2+} . Cytoplasmic alkalization or vacuolar acidification also promotes their opening under physiological conditions. The SV channels are regulated by $[\text{Ca}^{2+}]_{\text{cyt}}$ -dependent phosphorylation at two sites. Phosphorylation at one site is inhibitory, whereas phosphorylation at the other site activates the channel. It has been proposed that $[\text{Ca}^{2+}]_{\text{cyt}}$ -dependent regulation of SV channels might prevent an excessive rise in $[\text{Ca}^{2+}]_{\text{cyt}}$ or modulate the kinetics of changes in $[\text{Ca}^{2+}]_{\text{cyt}}$ (Sanders *et al.*, 1999). The activity of SV channels is also reduced by 14-3-3 proteins (van den Wijngaard *et al.*, 2001). The genes(s) encoding SV channels are unknown, but KCO1 has been implicated in their formation, since SV-channel currents in mesophyll protoplasts from the arabidopsis *kco1* mutant are smaller than those from wild-type plants (Schonknecht *et al.*, 2002). At least two types of pharmacologically distinct hyperpolarization-activated, Ca^{2+} -permeable channels (HACC) have been reported in plant vacuoles (Allen and Sanders, 1997; White, 2000). These open at trans-tonoplast voltages within the physiological range (-20 to -70 mV) and catalyse Ca^{2+} influx to the cytoplasm. Both tonoplast HACCs show spontaneous changes in their kinetic behaviour, which has been interpreted as resulting from interactions with (hypothetical) regulatory ligands. One type of tonoplast HACC is inhibited by a $[\text{Ca}^{2+}]_{\text{cyt}}$ above $1 \mu\text{M}$, whereas the other type is insensitive to $[\text{Ca}^{2+}]_{\text{cyt}}$. The opening of the second type of HACC is promoted by increasing $[\text{Ca}^{2+}]_{\text{vac}}$ and/or vacuolar alkalization.

Several highly selective Ca^{2+} channels activated by cytosolic second messengers (IP_3 , IP_6 or cADPR) are also present in the tonoplast (Allen and Sanders, 1997; White, 2000; Sanders *et al.*, 2002). All mediate Ca^{2+} influx to the cytoplasm. The IP_3 -dependent Ca^{2+} channels are activated half-maximally by IP_3 concentrations as low as 200 nM . They open at physiological trans-tonoplast voltages, and their opening is promoted by tonoplast hyperpolarization. They may have a role in turgor regulation in response to salt and hyper-osmotic stresses (Allen and Sanders, 1997; Drøbak and Watkins, 2000; DeWald *et al.*, 2001; Xiong *et al.*, 2002), in nastic movements (Kim *et al.*, 1996), in gravitropic movements of roots (Fasano *et al.*, 2002) and pulvini (Perera *et al.*, 1999), in stomatal closure (Staxén *et al.*, 1999; Blatt, 2000a, b; Ng *et al.*, 2001b; Schroeder *et al.*, 2001; Klüsener *et al.*, 2002) and in pollen tube elongation (Malhó *et al.*, 1998; Rudd and Franklin-Tong,

2001). They may also have roles in pollen tube self-incompatibility (Malhó *et al.*, 1998; Rudd and Franklin-Tong, 2001) and in plant defence responses (Mithöfer *et al.*, 1999; Sanders *et al.*, 1999; Blume *et al.*, 2000). The cADPR-dependent Ca^{2+} channels also open at physiological trans-tonoplast voltages, but are inhibited by $[\text{Ca}^{2+}]_{\text{cyt}}$ greater than 600 nM (Leckie *et al.*, 1998). The pharmacology of plant cADPR-dependent Ca^{2+} channels resembles that of the cADPR-activated, ryanodine-receptor channels found in the endomembranes of animal cells (Allen and Sanders, 1997). They are activated half-maximally by 20 – 40 nM cADPR, 20 nM ryanodine or millimolar concentrations of caffeine. They are inhibited by micromolar concentrations of ruthenium red and procaine. The cADPR-dependent Ca^{2+} channels have been implicated in ABA-signalling pathways leading to cold acclimation, desiccation tolerance (Wu *et al.*, 1997) and stomatal closure (Leckie *et al.*, 1998; Klüsener *et al.*, 2002), in circadian $[\text{Ca}^{2+}]_{\text{cyt}}$ rhythms and in the activation of plant defence responses (Durner *et al.*, 1998; Klessig *et al.*, 2000). Evidence for Ca^{2+} channels activated by sub-micromolar concentrations of IP_6 and having a role in stomatal closure is circumstantial but persuasive (Lemtiri-Chlieh *et al.*, 2000).

A variety of voltage-dependent and ligand-activated Ca^{2+} channels have also been revealed in the ER using biochemical or electrophysiological techniques (White, 2000). Depolarization-activated Ca^{2+} channels were observed when ER vesicles from the touch-sensitive tendrils of *Bryonia dioica* (BCC1) (Klüsener *et al.*, 1995) or the root tips of *Lepidium sativum* (LCC1) (Klüsener and Weiler, 1999) were incorporated into planar lipid bilayers. Their activities were modulated by the Ca^{2+} gradient across the ER membrane and enhanced by cytoplasmic acidification. An interesting model for the generation of oscillations in $[\text{Ca}^{2+}]_{\text{cyt}}$ through BCC1 has been proposed (Klüsener *et al.*, 1995). At the resting membrane potential of the ER, which is assumed to be close to zero, and with submicromolar Ca^{2+} activities in the lumen of the ER, BCC1 is likely to be closed. However, if the luminal Ca^{2+} activity is increased, for example by the activity of an ER Ca^{2+} -ATPase, BCC1 will open to release Ca^{2+} into the cytoplasm. This reduces the luminal Ca^{2+} and the channel recloses. This cycle will generate transient local elevations of $[\text{Ca}^{2+}]_{\text{cyt}}$. The frequency of these elevations could be determined by modulation of BCC1, the Ca^{2+} -ATPase or the Ca^{2+} gradient across the ER. In addition to these voltage-dependent Ca^{2+} channels, biochemical studies indicate the presence of Ca^{2+} channels activated by cADPR (Navazio *et al.*, 2001), NAADP (nicotinic acid adenine dinucleotide phosphate) (Navazio *et al.*, 2000) and (possibly) IP_3 (Muir and Sanders, 1997). To date, no genes encoding ER Ca^{2+} channels have been identified in plants, and there appear to be no plant genes homologous to the IP_3 -receptors, cADPR-receptors, NAADP-receptors or endomembrane voltage-gated channels of animals.

A hyperpolarization-activated Ca^{2+} -permeable channel has been recorded in excised patches from the nuclear envelope of red beet cells (Grygorczyk and Grygorczyk, 1998). This channel was unaffected by changes in $[\text{Ca}^{2+}]_{\text{cyt}}$, but when the $[\text{Ca}^{2+}]$ of the perinuclear space (the lumen of

the nuclear envelope) exceeded about 1 μM the channel opened at physiological voltages. Based on this observation, a role for this channel in regulating Ca^{2+} -dependent nuclear processes was proposed (Grygorczyk and Grygorczyk, 1998). Interestingly, annexin-like proteins with the potential to form Ca^{2+} -permeable cation channels have been located at the perinuclear membrane and in the nucleolus (Clark *et al.*, 1998; Kovács *et al.*, 1998; de Carvalho-Niebel *et al.*, 2002).

CYTOSOLIC CALCIUM SIGNALS

The evolution of $[\text{Ca}^{2+}]_{\text{cyt}}$ signalling and the $[\text{Ca}^{2+}]_{\text{cyt}}$ 'signature'

The $[\text{Ca}^{2+}]_{\text{cyt}}$ of plant cells increases in response to many developmental cues and environmental challenges (Table 2). This is considered essential for producing a physiological response. It is thought that elevating $[\text{Ca}^{2+}]_{\text{cyt}}$ is a primitive, and universal, response to stress. Sanders *et al.* (1999) observed that the low solubility product of Ca^{2+} and phosphate would have necessitated a $[\text{Ca}^{2+}]_{\text{cyt}}$ lower than the $[\text{Ca}^{2+}]$ of seawater to maintain energy metabolism. They presumed that this required the early evolution of mechanisms to remove Ca^{2+} from the cytoplasm, and noted that a homeostatically maintained submicromolar $[\text{Ca}^{2+}]_{\text{cyt}}$ would have been ideal for the subsequent evolution of $[\text{Ca}^{2+}]_{\text{cyt}}$ signalling systems, since it would confer sensitivity and speed to any signal. Sanders *et al.* (1999) also noted that the chemistry of Ca^{2+} , which can coordinate six to eight uncharged oxygen atoms, had fortuitously made possible the evolution of proteins that change conformation upon binding Ca^{2+} , allowing the cellular perception and transduction of a $[\text{Ca}^{2+}]_{\text{cyt}}$ signal.

To effect an appropriate physiological response to a particular stimulus, it is thought that the $[\text{Ca}^{2+}]_{\text{cyt}}$ perturbation (termed the $[\text{Ca}^{2+}]_{\text{cyt}}$ 'signature') elicited by each developmental cue or environmental challenge is unique. This uniqueness is manifest in the sub-cellular location and/or the kinetics or magnitude of the $[\text{Ca}^{2+}]_{\text{cyt}}$ perturbation (McAinsh and Hetherington, 1998; Trewavas, 1999; Rudd and Franklin-Tong, 2001). An increase in $[\text{Ca}^{2+}]_{\text{cyt}}$ is effected by Ca^{2+} influx to the cytosol either from the apoplast, across the plasma membrane, or from intracellular stores such as the ER or vacuole. This Ca^{2+} influx is mediated by Ca^{2+} -permeable ion channels, and their type, cellular location and abundance will influence the spatial characteristics of $[\text{Ca}^{2+}]_{\text{cyt}}$ perturbations. Since the diffusion of Ca^{2+} within the cytoplasm is low (Clapham, 1995), and the buffering of Ca^{2+} in the cytoplasm is high (0.1 to 1 mM; Malhó *et al.*, 1998; Trewavas, 1999), the opening of a Ca^{2+} channel produces a local increase in $[\text{Ca}^{2+}]_{\text{cyt}}$ that dissipates rapidly after the channel has closed. The subcellular localization of Ca^{2+} channels is therefore critical for the targeting of different cellular processes. In some circumstances, the proteins responding to the changes in $[\text{Ca}^{2+}]_{\text{cyt}}$ must either be associated with the Ca^{2+} channel itself or tethered closely to the membrane. Thus, the opening of Ca^{2+} channels influences local biochemical processes.

To coordinate cellular responses, $[\text{Ca}^{2+}]_{\text{cyt}}$ 'waves' are produced within the cytoplasm by the successive recruitment of receptive Ca^{2+} channels. Various authors have speculated how these waves might be initiated and propagated. Trewavas (1999) suggested that a local elevation of $[\text{Ca}^{2+}]_{\text{cyt}}$ might generate soluble second messengers, such as IP_3 or cADPR, that diffuse through the cytoplasm to activate a relay of spatially separated Ca^{2+} -channels. This might occur during the $[\text{Ca}^{2+}]_{\text{cyt}}$ waves observed in the shank of poppy pollen tubes during the self-incompatibility response (Straatman *et al.*, 2001; Rudd and Franklin-Tong, 2001) or in plant cells responding to salt stress (Drøbak and Watkins, 2000). Antoine *et al.* (2001) suggested that the $[\text{Ca}^{2+}]_{\text{cyt}}$ wave that crosses the egg following fertilization was the result of the successive activation of (mechanosensitive) Ca^{2+} channels in the plasma membrane radiating from the site of sperm entry, and Franklin-Tong *et al.* (2002) suggested that repetitive Ca^{2+} influx across the plasma membrane contributed to the $[\text{Ca}^{2+}]_{\text{cyt}}$ waves that occurred in the shank of poppy pollen tubes during the self-incompatibility response. The spatial changes in elevated $[\text{Ca}^{2+}]_{\text{cyt}}$ that occur following the application of ABA to guard cells, first close to the plasma membrane and subsequently adjacent to the vacuole (McAinsh *et al.*, 1992; Allen *et al.*, 1999), are thought to reflect the sequential opening of hyperpolarization-activated Ca^{2+} channels at the plasma membrane and then second-messenger activated Ca^{2+} channels in the tonoplast (Grabov and Blatt, 1998; White, 2000; Schroeder *et al.*, 2001). In addition to these subcellular $[\text{Ca}^{2+}]_{\text{cyt}}$ waves, 'waves' of cells with high $[\text{Ca}^{2+}]_{\text{cyt}}$ may also propagate through plant tissues. These can be induced in root tissues by mechanical stimulation (Legué *et al.*, 1997; Fasano *et al.*, 2002) or saline shock (Moore *et al.*, 2002), in cotyledons by cold shock (Knight *et al.*, 1993) and in leaves by chilling plant roots briefly (Campbell *et al.*, 1996). Electrical action potentials, osmotic perturbations or chemical signals may trigger these waves.

Although an elevated $[\text{Ca}^{2+}]_{\text{cyt}}$ is necessary for signal transduction, a prolonged increase in $[\text{Ca}^{2+}]_{\text{cyt}}$ is lethal. Indeed, sustained high $[\text{Ca}^{2+}]_{\text{cyt}}$ is implicated in apoptosis, both during normal development (e.g. in tissue patterning and xylogenesis) and in hypersensitive responses to pathogens (Levine *et al.*, 1996). To effect other responses, $[\text{Ca}^{2+}]_{\text{cyt}}$ perturbations must be either of low amplitude or transient. Transient increases in $[\text{Ca}^{2+}]_{\text{cyt}}$ can be single (spike), double (biphasic) or multiple (oscillations). Unique $[\text{Ca}^{2+}]_{\text{cyt}}$ spikes can be generated by delaying the $[\text{Ca}^{2+}]_{\text{cyt}}$ rise, or by altering the rate of change of $[\text{Ca}^{2+}]_{\text{cyt}}$, the maximal $[\text{Ca}^{2+}]_{\text{cyt}}$ reached or the duration $[\text{Ca}^{2+}]_{\text{cyt}}$ is above a certain threshold. Oscillations can differ in their $[\text{Ca}^{2+}]_{\text{cyt}}$ amplitudes, periodicity or duration (Evans *et al.*, 2001). The production of $[\text{Ca}^{2+}]_{\text{cyt}}$ waves allows specific spatiotemporal $[\text{Ca}^{2+}]_{\text{cyt}}$ perturbations to be generated that may differ in their cellular location, rate and extent of propagation and/or their $[\text{Ca}^{2+}]_{\text{cyt}}$ amplitude during propagation (Malhó *et al.*, 1998). However, despite the seductive logic of a $[\text{Ca}^{2+}]_{\text{cyt}}$ signature for each developmental cue or environmental challenge, plant tissues are comprised of populations of heterogeneous cells that may have contrasting abilities to

generate $[Ca^{2+}]_{cyt}$ signatures. For example, (a) within the root, the $[Ca^{2+}]_{cyt}$ perturbations induced by mechanical perturbation (Legué *et al.*, 1997), salinity, osmotic stress, cold shock or slow cooling (Kiegle *et al.*, 2000b; Moore *et al.*, 2002) differ markedly between cell types, and (b) shoot cells exhibit a biphasic $[Ca^{2+}]_{cyt}$ perturbation during anoxia, whereas only a slow increase in $[Ca^{2+}]_{cyt}$ is observed in root cells (Sedbrook *et al.*, 1996; Plieth, 2001). Indeed, even cells of the same type, such as the two guard cells of a stomate, seldom generate an identical $[Ca^{2+}]_{cyt}$ in response to a defined stimulus (Allen *et al.*, 1999). This heterogeneity may arise from differences in cellular cytology, the distribution of cytoplasmic Ca^{2+} buffers and/or the activities of Ca^{2+} transporters.

The $[Ca^{2+}]_{cyt}$ signature: temporal and spatial aspects

Several abiotic challenges result in an immediate, transient increase in $[Ca^{2+}]_{cyt}$ that is restored to basal levels within minutes (Table 2). Such challenges include mechanical perturbation (Knight *et al.*, 1991, 1992; Haley *et al.*, 1995; Legué *et al.*, 1997; Malhó *et al.*, 1998; van der Luit, 1999; Plieth, 2001; Fasano *et al.*, 2002) and rapid cooling for brief periods, termed 'cold-shock' (Knight *et al.*, 1991; Plieth *et al.*, 1999; van der Luit, 1999; Kiegle *et al.*, 2000b; Plieth, 2001). By contrast, sustained cooling below a threshold temperature results in a biphasic response in $[Ca^{2+}]_{cyt}$, in which an initial transient increase in $[Ca^{2+}]_{cyt}$ is followed by a more prolonged, second transient elevation of $[Ca^{2+}]_{cyt}$ (Plieth *et al.*, 1999; Knight, 2000; Knight and Knight, 2000; Moore *et al.*, 2002). Heat shock, acute salt (NaCl) stress, hyper-osmotic (mannitol) stress, anoxia and exposure to oxidative stress also elicit an immediate, transient increase in $[Ca^{2+}]_{cyt}$ in plant cells, which is followed by a more prolonged elevation of $[Ca^{2+}]_{cyt}$ lasting many minutes or hours (Table 2; McAinsh *et al.*, 1996; Sedbrook *et al.*, 1996; Knight *et al.*, 1997, 1998; Gong *et al.*, 1998; Clayton *et al.*, 1999; Kiegle *et al.*, 2000b; Knight, 2000; DeWald *et al.*, 2001; Plieth, 2001; Lecourieux *et al.*, 2002; Moore *et al.*, 2002). Biphasic $[Ca^{2+}]_{cyt}$ perturbations have been observed in plant cells in response to diverse pathogens and elicitors, but the kinetics of these responses varies greatly (Lecourieux *et al.*, 2002). Rudd and Franklin-Tong (2001) speculated that the slow generation of a sustained $[Ca^{2+}]_{cyt}$ elevation was a common feature of these responses, and the sustained increase in $[Ca^{2+}]_{cyt}$ alone was subsequently correlated with the induction of defence responses (Cessna and Low, 2001; Lecourieux *et al.*, 2002).

Several developmental cues and environmental challenges produce $[Ca^{2+}]_{cyt}$ oscillations (Table 2). The duration, periodicity and amplitude of $[Ca^{2+}]_{cyt}$ oscillations vary considerably, and their form is often dependent on the strength and combination of specific stimuli (Felle, 1988; McAinsh *et al.*, 1995; Allen *et al.*, 1999; Staxén *et al.*, 1999; Evans *et al.*, 2001). Periodicities may range from the circadian oscillations observed in various plant cells (Johnson *et al.*, 1995; Wood *et al.*, 2001), through the slow oscillations observed in coleoptile cells following the addition of auxin (periodicity ≈ 30 min; Felle, 1988) and in guard cells either spontaneously or in response to stimuli

such as ABA, $[Ca^{2+}]_{ext}$, ozone, cold-shock and elicitors (periodicity >3 min; Grabov and Blatt, 1998; Allen *et al.*, 1999, 2000; Staxén *et al.*, 1999; Evans *et al.*, 2001; Ng *et al.*, 2001a; Klüsener *et al.*, 2002), to the rapid oscillations in $[Ca^{2+}]_{cyt}$ observed at the tip of growing pollen tubes (periodicity 40–75 s; Holdaway-Clarke *et al.*, 1997; Malhó *et al.*, 1998, 2000; Messerli *et al.*, 2000; Rudd and Franklin-Tong, 2001) and in root hairs during nodulation (periodicity 1–2 min; Wais *et al.*, 2000; Walker *et al.*, 2000; Shaw and Long, 2003). It is noteworthy that oscillations can be induced in guard cells by releasing caged Ca^{2+} into the cytosol (McAinsh *et al.*, 1995) and oscillatory $[Ca^{2+}]_{cyt}$ waves can be induced in pollen tubes by releasing caged Ca^{2+} or IP_3 into the cytosol (Malhó and Trewavas, 1996; Malhó, 1998). Several hypotheses have been proposed for the generation of $[Ca^{2+}]_{cyt}$ oscillations. These include models based on the successive emptying and refilling of finite Ca^{2+} stores (Klüsener *et al.*, 1995; Harper, 2001), on the successive activation and deactivation of target Ca^{2+} channels through co-incident signalling cascades (Sanders *et al.*, 1999; White, 2000) or by the stretching and relaxation of a membrane (Holdaway-Clarke *et al.*, 1997).

Different stimuli generate contrasting spatial $[Ca^{2+}]_{cyt}$ perturbations by mobilizing Ca^{2+} from different cellular stores and/or by activating Ca^{2+} channels in a restricted location (Table 2; Sanders *et al.*, 1999). For example, Ca^{2+} influx from the apoplast is implicated in elevating $[Ca^{2+}]_{cyt}$ during brief cold-shock (White, 1998, 2000; Plieth *et al.*, 1999; Kiegle *et al.*, 2000b; Knight, 2000; Plieth, 2001) and oxidative stress (Knight *et al.*, 1997; Clayton *et al.*, 1999), but release from internal stores contributes significantly to the $[Ca^{2+}]_{cyt}$ elevations in response to prolonged cooling, salinity, osmotic stresses or pathogens (Knight *et al.*, 1996, 1997; Blume *et al.*, 2000; Knight, 2000; Pauly *et al.*, 2001; Lecourieux *et al.*, 2002; Moore *et al.*, 2002) and dominates the $[Ca^{2+}]_{cyt}$ elevations in response to mechanical perturbations (Haley *et al.*, 1995; Legué *et al.*, 1997) and anoxia (Subbaiah *et al.*, 1994, 1998). Van der Luit *et al.* (1999) demonstrated that separate nuclear $[Ca^{2+}]$ and $[Ca^{2+}]_{cyt}$ perturbations were initiated in tobacco seedlings in response to wind and cold shock, respectively, and that each led to the expression of a different CaM isoform. Pauly *et al.* (2001) similarly proposed that different cytoplasmic and nuclear signals were involved in discriminating between hypo- and hyper-osmotic shock.

Graded $[Ca^{2+}]_{cyt}$ responses to stimuli

Perturbations in $[Ca^{2+}]_{cyt}$ often show a graded response that is proportional to the strength of the stimulus. For example, the frequency and amplitude of oscillations in the $[Ca^{2+}]_{cyt}$ of guard cells varies directly with the apoplastic ABA (Staxén *et al.*, 1999) or sphingosine-1-phosphate (Ng *et al.*, 2001a) concentration, with corresponding effects on the kinetics of stomatal closure. The form of the $[Ca^{2+}]_{cyt}$ perturbations that occur during cooling are a complex function of the rate of cooling, the duration of cooling, and the magnitude of the temperature drop (Plieth *et al.*, 1999). Plant cells respond to a brief cold-shock with an immediate, transient increase in $[Ca^{2+}]_{cyt}$ that is proportional to the rate

TABLE 2. Examples of the developmental processes and responses to abiotic and biotic challenges initiated by a perturbation in cytosolic Ca^{2+} concentration ($[Ca^{2+}]_{cyt}$)

Developmental process or environmental challenge	Characteristic $[Ca^{2+}]_{cyt}$ perturbation	Stores releasing Ca^{2+} to cytosol	Selected references
Pollen tube elongation	Oscillation of high apical $[Ca^{2+}]_{cyt}$	Apoplast and internal	Malhó and Trewavas, 1996; Holdaway-Clarke <i>et al.</i> , 1997; Malhó <i>et al.</i> , 1998; 2000; Messerli <i>et al.</i> , 2000; Rudd and Franklin-Tong, 2001
Pollen tube self-incompatibility response	Intracellular $[Ca^{2+}]_{cyt}$ wave in shank	Apoplast Internal (IP ₃ -dependent)	Rudd and Franklin-Tong, 2001; Straatman <i>et al.</i> , 2001; Franklin-Tong <i>et al.</i> , 2002
Cell polarity after fertilization	Intracellular $[Ca^{2+}]_{cyt}$ wave from sperm fusion site leading to sustained $[Ca^{2+}]_{cyt}$ elevation	Apoplast	Antoine <i>et al.</i> , 2001
Cell division	Elevated $[Ca^{2+}]_{cyt}$		Bush, 1995
Seed germination (gibberellins)	Slow rise in $[Ca^{2+}]_{cyt}$		Bush, 1995; Anil and Sankara Rao, 2001
Apoptosis	Slow, sustained $[Ca^{2+}]_{cyt}$ elevation		Levine <i>et al.</i> , 1996
Red light	Elevated $[Ca^{2+}]_{cyt}$	Apoplast	Shacklock <i>et al.</i> 1992; Malhó <i>et al.</i> , 1998
Blue light	Brief spike in $[Ca^{2+}]_{cyt}$ (seconds)	Apoplast	Malhó <i>et al.</i> , 1998; Baum <i>et al.</i> , 1999
Circadian rhythms	Circadian $[Ca^{2+}]_{cyt}$ oscillation		Johnson <i>et al.</i> , 1995; Wood <i>et al.</i> , 2001
Stomatal closure (ABA, sphingosine-1-phosphate)	(1) Elevated $[Ca^{2+}]_{cyt}$ at cell periphery (2) Elevated $[Ca^{2+}]_{cyt}$ around vacuole (3) Oscillations in $[Ca^{2+}]_{cyt}$	(1) Apoplast (2) Vacuole (3) Apoplast and internal	McAinsh <i>et al.</i> , 1992; Allen <i>et al.</i> , 1999, 2000; Blatt, 2000a, b; White, 2000; Anil and Sankara Rao, 2001; Evans <i>et al.</i> , 2001; Ng <i>et al.</i> , 2001a, b; Schroeder <i>et al.</i> , 2001; Klüsener <i>et al.</i> , 2002
CO ₂	Elevated $[Ca^{2+}]_{cyt}$ in guard cells	Apoplast	Webb <i>et al.</i> , 1996
Increasing apoplastic Ca ²⁺	Oscillations in $[Ca^{2+}]_{cyt}$ of guard cells	Apoplast	McAinsh <i>et al.</i> , 1995; Allen <i>et al.</i> , 1999, 2000
Auxin responses	(1) Slow, prolonged $[Ca^{2+}]_{cyt}$ increase (2) Oscillations in $[Ca^{2+}]_{cyt}$		Felle, 1988; Malhó <i>et al.</i> , 1998; Ng <i>et al.</i> , 2001b; Plieth, 2001; Plieth and Trewavas, 2002
Xylem K ⁺ loading	Elevated $[Ca^{2+}]_{cyt}$		De Boer, 1999
Exocytosis	Elevated $[Ca^{2+}]_{cyt}$		Battey <i>et al.</i> , 1999; Camacho and Malhó, 2003
Root cell elongation	Sustained $[Ca^{2+}]_{cyt}$ elevation	Apoplast	Cramer and Jones, 1996; Demidchik <i>et al.</i> , 2002a
Root hair elongation	Sustained high apical $[Ca^{2+}]_{cyt}$	Apoplast	Wymer <i>et al.</i> , 1997; White, 1998; Bibikova <i>et al.</i> , 1999
Inhibition of cyclosis	Elevated $[Ca^{2+}]_{cyt}$		Ayling and Clarkson, 1996
Nodulation (nod factors)	Initial $[Ca^{2+}]_{cyt}$ rise then oscillations in $[Ca^{2+}]_{cyt}$	Apoplast	Cárdenas <i>et al.</i> , 2000; Wais <i>et al.</i> , 2000; Walker <i>et al.</i> , 2000; Lhuissier <i>et al.</i> , 2001; Shaw and Long, 2003
Senescence	Sustained $[Ca^{2+}]_{cyt}$ elevation		Huang <i>et al.</i> , 1997
UV-B	Slow $[Ca^{2+}]_{cyt}$ rise, elevated $[Ca^{2+}]_{cyt}$ sustained for several minutes	Apoplast	Frohnmeier <i>et al.</i> , 1999
Heat-shock	Elevated $[Ca^{2+}]_{cyt}$ sustained for 15–30 min	Apoplast and internal (IP ₃ -dependent)	Gong <i>et al.</i> , 1998; Malhó <i>et al.</i> , 1998
Cold-shock	(1) Single brief $[Ca^{2+}]_{cyt}$ spike (seconds) (2) Oscillations in $[Ca^{2+}]_{cyt}$	(1) Apoplast	Knight <i>et al.</i> , 1991; Malhó <i>et al.</i> , 1998; White, 1998; Plieth <i>et al.</i> , 1999; van der Luit, 1999; Allen <i>et al.</i> , 2000; Kiegle <i>et al.</i> , 2000b; Knight, 2000; Cessna <i>et al.</i> , 2001; Plieth, 2001
Slow cooling	Biphasic (1) Brief $[Ca^{2+}]_{cyt}$ spike (seconds) (2) Slow $[Ca^{2+}]_{cyt}$ elevation (minutes)	(1) Apoplast (2) Apoplast and internal (IP ₃ -dependent)	Knight <i>et al.</i> , 1996; Plieth <i>et al.</i> , 1999; Knight, 2000; Knight and Knight, 2000; Moore <i>et al.</i> , 2002

TABLE 2. Continued

Developmental process or environmental challenge	Characteristic $[Ca^{2+}]_{cyt}$ perturbation	Stores releasing Ca^{2+} to cytosol	Selected references
Oxidative stress (paraquat, superoxide, H_2O_2 , ozone)	(1) Brief $[Ca^{2+}]_{cyt}$ spike (2) Sustained $[Ca^{2+}]_{cyt}$ elevation (3) Oscillations in $[Ca^{2+}]_{cyt}$	(1) Apoplast (2) Apoplast and internal (IP ₃ -dependent)	Price <i>et al.</i> , 1994; Levine <i>et al.</i> , 1996; McAinsh <i>et al.</i> , 1996; Knight <i>et al.</i> , 1998; Malhó <i>et al.</i> , 1998; Clayton <i>et al.</i> , 1999; Allen <i>et al.</i> , 2000; Kawano and Muto, 2000; Knight, 2000; Klüsener <i>et al.</i> , 2002; Lecourieux <i>et al.</i> , 2002
Anoxia	Biphasic (1) Slow spike (duration of minutes) (2) Sustained $[Ca^{2+}]_{cyt}$ elevation (hours)	(1) Apoplast (2) Internal including mitochondria	Subbaiah <i>et al.</i> , 1994, 1998; Sedbrook <i>et al.</i> , 1996; Malhó <i>et al.</i> , 1998; Plieth, 2001
Drought/hyper-osmotic stress (mannitol)	Biphasic (1) Slow spike (duration of minutes) (2) Sustained $[Ca^{2+}]_{cyt}$ elevation (hours)	Apoplast and vacuole	Knight <i>et al.</i> , 1997, 1998; Malhó <i>et al.</i> , 1998; Kiegle <i>et al.</i> , 2000b; Cessna <i>et al.</i> , 2001; Pauly <i>et al.</i> , 2001; Plieth, 2001
Salinity (NaCl)	Biphasic Tissue $[Ca^{2+}]_{cyt}$ wave (1) Slow spike (duration of minutes) (2) Sustained $[Ca^{2+}]_{cyt}$ elevation (hours) (3) Reduced $[Ca^{2+}]_{cyt}$ (days)	Apoplast and vacuole (IP ₃ -dependent)	Knight <i>et al.</i> , 1997; Kiegle <i>et al.</i> , 2000b; Knight, 2000; DeWald <i>et al.</i> , 2001; Pauly <i>et al.</i> , 2001; Moore <i>et al.</i> , 2002; Halperin <i>et al.</i> , 2003
Hypo-osmotic stress	Biphasic (1) Small $[Ca^{2+}]_{cyt}$ elevation (2) Large $[Ca^{2+}]_{cyt}$ elevation	(1) Apoplast (2) Apoplast and internal (IP ₃ -dependent)	Takahashi <i>et al.</i> , 1997; Malhó <i>et al.</i> , 1998; Knight, 2000; Cessna and Low, 2001; Cessna <i>et al.</i> , 2001; Pauly <i>et al.</i> , 2001; Plieth, 2001
Mechanical stimulation (motion, touch, wind)	Single brief $[Ca^{2+}]_{cyt}$ spike (seconds) Tissue $[Ca^{2+}]_{cyt}$ wave	Internal	Knight <i>et al.</i> , 1991, 1992; Haley <i>et al.</i> , 1995; Legue <i>et al.</i> , 1997; Malhó <i>et al.</i> , 1998; van der Luit, 1999; Plieth, 2001; Fasano <i>et al.</i> , 2002
Aluminium stress	Elevated $[Ca^{2+}]_{cyt}$		Zhang and Rengel, 1999
Pathogens (elicitors)	Biphasic (1) Slow spike (duration of minutes) (2) Sustained $[Ca^{2+}]_{cyt}$ elevation (hours) (3) Oscillations in $[Ca^{2+}]_{cyt}$ (the relative magnitude of different phases varies with elicitor identity)	(1) Apoplast (2) Apoplast and internal (IP ₃ -dependent)	Knight <i>et al.</i> , 1991; Malhó <i>et al.</i> , 1998; Mithöfer <i>et al.</i> , 1999; Blume <i>et al.</i> , 2000; Fellbrich <i>et al.</i> , 2000; Grant <i>et al.</i> , 2000; Cessna and Low 2001; Cessna <i>et al.</i> 2001; Rudd and Franklin-Tong, 2001; Klüsener <i>et al.</i> , 2002; Lecourieux <i>et al.</i> , 2002

The kinetics of the $[Ca^{2+}]_{cyt}$ perturbations and the location of stores releasing Ca^{2+} into the cytosol associated with each developmental process or environmental challenge are indicated.

of cooling, whereas they respond to sustained cooling below a threshold temperature with a prolonged biphasic $[Ca^{2+}]_{cyt}$ perturbation (Table 2). The magnitude of the $[Ca^{2+}]_{cyt}$ elevation induced in roots following their reorientation in a gravitational field is proportional to the angle of displacement up to a maximum of 135°, which corresponds to the optimal angle for amyloplasts to slide down the cell wall (Plieth and Trewavas, 2002), and the $[Ca^{2+}]_{cyt}$ perturbation induced by mechanical stimulation is increased in proportion to the stress and/or the time an organ is in motion (Knight *et al.*, 1992; Haley *et al.*, 1995). Similarly, the magnitude of the initial $[Ca^{2+}]_{cyt}$ elevation induced in tobacco suspension cells by hypo- or hyper-osmotic shock depends upon the change in the osmolarity of the bathing medium (Takahashi *et al.*, 1997; Pauly *et al.*, 2001), the magnitude of the $[Ca^{2+}]_{cyt}$ perturbation in response to

elicitors increases proportionally to the elicitor concentration applied (Mithöfer *et al.*, 1999; Blume *et al.*, 2000; Lecourieux *et al.*, 2002) and the magnitude of the $[Ca^{2+}]_{cyt}$ elevation induced by oxidative stress increases in proportion to the concentrations of ozone, H_2O_2 or methyl viologen applied (Price *et al.*, 1994; Levine *et al.*, 1996; McAinsh *et al.*, 1996; Clayton *et al.*, 1999; Lecourieux *et al.*, 2002).

Explicit $[Ca^{2+}]_{cyt}$ perturbations produce defined physiological responses

Explicit $[Ca^{2+}]_{cyt}$ signatures are responsible for the activation of specific genes in animal cells (Dolmetsch *et al.*, 1997, 1998; Li *et al.*, 1998). This is consistent with the hypothesis that explicit $[Ca^{2+}]_{cyt}$ signatures produce defined physiological responses to specific developmental cues or

environmental challenges. However, there have been few attempts to generate explicit $[Ca^{2+}]_{cyt}$ perturbations artificially in plants. Although several experiments have demonstrated that elevating $[Ca^{2+}]_{cyt}$ using ionophores induces the expression of Ca^{2+} -dependent genes and physiological responses to chilling and ABA (Monroy and Dhinsa, 1995; Sheen, 1996), the $[Ca^{2+}]_{cyt}$ perturbations produced by ionophores are unlikely to have the same form as the $[Ca^{2+}]_{cyt}$ perturbations elicited by these effectors. This suggested to Plieth (2001) that the form of the $[Ca^{2+}]_{cyt}$ signature was inconsequential for these responses. Indeed, Plieth (2001) further argued that the notion of an explicit $[Ca^{2+}]_{cyt}$ signature entirely responsible for a defined physiological response was fundamentally doubtful. He cited these observations: (a) both osmotic stress and salt stress induced similar $[Ca^{2+}]_{cyt}$ perturbations, but result in different levels of expression of the *p5cs* gene (Knight *et al.*, 1997), and (b) almost any $[Ca^{2+}]_{cyt}$ perturbation could be elicited in plant cells with an appropriate manipulation of temperature (Plieth, 2001), to suggest that factors other than, or in addition to, $[Ca^{2+}]_{cyt}$ were involved in producing an appropriate response to a particular challenge. Consistent with this suggestion, $[Ca^{2+}]_{cyt}$ transients have recently been found to be necessary, but not sufficient, for the expression of ABA-inducible genes in plant cells (Webb *et al.*, 2001). Nevertheless, several biochemical and genetic consequences have been attributed to specific $[Ca^{2+}]_{cyt}$ signatures.

An insight into the $[Ca^{2+}]_{cyt}$ signatures required for specific cellular responses has been obtained by correlating biochemical or genetic responses with particular characteristics of $[Ca^{2+}]_{cyt}$ perturbations common to diverse stimuli or by dissecting $[Ca^{2+}]_{cyt}$ perturbations using pharmaceuticals. Thus, Cessna and Low (2001) used pharmaceuticals to alter the $[Ca^{2+}]_{cyt}$ perturbations in response to hypo-osmotic shock to demonstrate that only the Ca^{2+} flux from internal stores during the second transient increase in $[Ca^{2+}]_{cyt}$ initiated an oxidative burst. They speculated that this was a consequence of either a local elevation of $[Ca^{2+}]_{cyt}$ and/or a local distribution of the enzymes generating H_2O_2 . Similarly, Lecourieux *et al.* (2002) demonstrated that only the second, sustained increase in $[Ca^{2+}]_{cyt}$ elicited by cryptogein was required for a hypersensitive response and cell death. Blume *et al.* (2000) demonstrated that only a sustained $[Ca^{2+}]_{cyt}$ elevation induced phytoalexin synthesis in response to elicitors, and Clayton *et al.* (1999) showed that the induction of glutathione-S-transferase (*GST*) gene expression by ozone relied only on the second, transient $[Ca^{2+}]_{cyt}$ elevation. Finally, the changes in $[Ca^{2+}]_{cyt}$ perturbations following combinations of oxidative stress and hyper-osmotic stress correlated well with the expression of Ca^{2+} -regulated osmotic stress induced genes (*p5cs* and *rab18*), and the acquisition of osmotic stress tolerance (Knight *et al.*, 1998).

A direct demonstration that an explicit $[Ca^{2+}]_{cyt}$ perturbation was required to produce a defined physiological response was performed recently on arabidopsis guard cells (Allen *et al.*, 2001). Artificially elevating $[Ca^{2+}]_{cyt}$ in guard cells through hyperpolarization (Grabov and Blatt, 1998; Allen *et al.*, 2000, 2001) or H_2O_2 (Allen *et al.*, 2000; Pei *et al.*, 2000) can induce stomatal closure. However,

although a single elevation of $[Ca^{2+}]_{cyt}$ was sufficient for immediate stomatal closure, prolonged stomatal closure could only be induced if the initial increase in $[Ca^{2+}]_{cyt}$ was followed by $[Ca^{2+}]_{cyt}$ oscillations with a specific periodicity (Allen *et al.*, 2001). Interestingly, appropriate $[Ca^{2+}]_{cyt}$ oscillations are induced in guard cells by ABA and stomates of the ABA-insensitive mutant *gca2*, which shows aberrant $[Ca^{2+}]_{cyt}$ oscillations in response to ABA, can be induced to close when appropriate $[Ca^{2+}]_{cyt}$ are produced artificially (Allen *et al.*, 2001).

Habituation, 'learning' and 'memory'

Trewavas (1999) has likened the $[Ca^{2+}]_{cyt}$ signalling network to a basic cellular 'memory'. He noted that, in common with a neural network, $[Ca^{2+}]_{cyt}$ signals have the following properties: they may be (a) spatially structured, through the occurrence and location of cellular components; (b) subject to coincidence control, since certain elements are the targets of multiple $[Ca^{2+}]_{cyt}$ cascades and can process or block specific signals arriving coincidentally; (c) synchronized, for example by membrane depolarization or a sudden increase in the concentration of a diffusible second messenger; (d) modified by exposure to specific challenges, through changes in the abundance of cellular components involved in $[Ca^{2+}]_{cyt}$ signals; and (e) predisposed by previous challenges to generate an appropriate $[Ca^{2+}]_{cyt}$ signal in response to a current challenge. He suggested that these prerequisites for cellular 'learning' allow plant cells to respond 'intelligently' to the challenges they experience through an innate phenotypic and physiological plasticity.

Previous sections have discussed the spatial distribution of Ca^{2+} -transporters within a plant cell and their modulation by components of diverse intracellular signalling cascades such as $[Ca^{2+}]_{cyt}$, cytoplasmic pH, reactive oxygen species, kinases, phosphatases, cNMPs, IP_3 and cADPR. Such Ca^{2+} transporters could be a point of convergence, and integration, of many developmental and environmental signals. This phenomenon is termed 'cross-talk' and might be a mechanism whereby plants develop cross-tolerance to various biotic and abiotic stresses (Bowler and Fluhr, 2000; Knight, 2000). Similarly many targets of $[Ca^{2+}]_{cyt}$ signals are also regulated by components of diverse signalling cascades (see below).

There is considerable evidence that $[Ca^{2+}]_{cyt}$ signatures are modified by previous experience. A diminished $[Ca^{2+}]_{cyt}$ elevation upon repetitive stimulation and/or a refractory period during which an increase in $[Ca^{2+}]_{cyt}$ cannot be elicited by the same developmental cue or environmental challenge is commonly observed. The magnitude of the $[Ca^{2+}]_{cyt}$ perturbation elicited by reorientation in a gravitational field (Plieth and Trewavas, 2002), touch (Legué *et al.*, 1997) or wind-induced motion (Knight *et al.*, 1992) becomes progressively smaller upon repeated stimulation and a refractory period of several minutes is required before a full response is observed again. Following one brief pulse of phototropically active blue light, arabidopsis seedlings will not respond maximally again for several hours (Baum *et al.*, 1999). A second exposure to an elicitor does not influence $[Ca^{2+}]_{cyt}$ for several hours after its initial applic-

ation (Blume *et al.*, 2000), and plant cells challenged with H_2O_2 fail to respond to H_2O_2 again for several hours (Price *et al.*, 1994). An anoxic treatment reduces the magnitude of the initial $[Ca^{2+}]_{cyt}$ peak and delays the sustained elevation of $[Ca^{2+}]_{cyt}$ in response to a second anoxic treatment (Sedbrook *et al.*, 1996), and the magnitude of $[Ca^{2+}]_{cyt}$ perturbations is diminished by continued chilling and rewarming (Plieth *et al.*, 1999). These observations may indicate a desensitization of signalling cascades or a depletion of stores releasing Ca^{2+} to the cytosol. By contrast, the magnitude of the second (vacuolar) $[Ca^{2+}]_{cyt}$ elevation observed during slow cooling was increased following a period of cold acclimation (Knight and Knight, 2000), and a pretreatment with mannitol increased the magnitude of the $[Ca^{2+}]_{cyt}$ perturbations subsequently induced by hyper-osmotic shock (Knight *et al.*, 1998).

There is also evidence that the $[Ca^{2+}]_{cyt}$ signatures elicited by one environmental challenge can be modified by prior exposure to a contrasting one. For example, the magnitude of the $[Ca^{2+}]_{cyt}$ perturbations in response to oxidative stress was reduced by a prior exposure to hyper-osmotic stress (Knight *et al.*, 1997; Knight, 2000), and the magnitude of the $[Ca^{2+}]_{cyt}$ perturbations in response to hyper-osmotic stress was reduced by a prior exposure to oxidative stress (Knight *et al.*, 1998; Knight, 2000). These observations may imply cross-talk between the signalling cascades and/or Ca^{2+} channels and stores responding to these challenges. However, prior oxidative stress did not affect the $[Ca^{2+}]_{cyt}$ transient observed upon cold shock or touch (Price *et al.*, 1994; Knight *et al.*, 1998), suggesting that contrasting signalling cascades and/or Ca^{2+} stores and channels are recruited by these challenges. Similarly, during the refractory period following heat shock, during which additional heat shocks fail to elevate $[Ca^{2+}]_{cyt}$, $[Ca^{2+}]_{cyt}$ can be elevated by cold shock or mechanical perturbation (Gong *et al.*, 1998), and during the refractory period following wind-induced motion, cells can still raise $[Ca^{2+}]_{cyt}$ in response to cold shock (Knight *et al.*, 1992). The cross-talk (and lack of cross-talk) between diverse signalling cascades responding to each facet of the environment is thought to optimize a plant's response to its surroundings.

RESPONDING TO CYTOSOLIC CALCIUM SIGNALS

To respond appropriately to a specific $[Ca^{2+}]_{cyt}$ perturbation, a cell must activate a unique combination of Ca^{2+} -binding proteins. These $[Ca^{2+}]_{cyt}$ sensors include CaMs, CaM-like proteins, calcineurin B-like (CBL) proteins and Ca^{2+} -dependent protein kinases (CDPKs). Many of these proteins bind Ca^{2+} using a helix–loop–helix structure termed the 'EF hand', which binds a single Ca^{2+} molecule with high affinity (Strynadka and James, 1989). Frequently, pairs of EF hands interact through antiparallel β -sheets, which allows cooperativity in Ca^{2+} binding. When Ca^{2+} binds to $[Ca^{2+}]_{cyt}$ sensors their structural and/or enzymatic properties change and their subsequent interactions with target proteins can alter solute transport and enzymatic activities, cytoskeletal orientation, protein phosphorylation cascades and gene expression. It is believed that these changes result in stress

tolerance and/or a developmental switch. The form of the physiological response is determined not only by the $[Ca^{2+}]_{cyt}$ perturbation itself, but also by the expression of the $[Ca^{2+}]_{cyt}$ sensors, their affinities for both Ca^{2+} and target proteins, and the abundance and activity of the target proteins. Since different cell types, and probably even individuals of the same cell type, have contrasting transcript, protein and enzyme profiles, a similar $[Ca^{2+}]_{cyt}$ perturbation will result in individual responses, which may contribute to phenotypic plasticity (Gilroy and Trewavas, 2001).

Calcium-binding proteins: CaM and CaM-related proteins

CaM is found in the apoplast and in the cytosol, ER and nucleus of plant cells. Within the cytosol, the estimated CaM concentration is 5 to 40 μM (Zielinski, 1998). Calmodulin has been implicated in Ca^{2+} -dependent responses to light, gravity, mechanical stress, phytohormones, pathogens, osmotic stress, salinity, heavy metals, xenobiotics, annoxia, oxidative stress, heat shock and chilling (Zielinski, 1998; Snedden and Fromm, 2001; Reddy, 2001; Rudd and Franklin-Tong, 2001; Fasano *et al.*, 2002). Calmodulin is a small (17 kDa), highly conserved, acidic protein with two globular domains each containing two EF hands connected by a flexible α -helical spacer (Zielinski, 1998; Reddy, 2001; Snedden and Fromm, 2001; Luan *et al.*, 2002). A Ca^{2+} /CaM complex generally interacts with target proteins, although there are exceptions, such as the interaction of myosin-like proteins with CaM alone (Reddy, 2001). The binding of Ca^{2+} to CaM, which has a K_d between 10^{-7} and 10^{-6} M, exposes a hydrophobic surface on each globular domain. This enables the Ca^{2+} /CaM complex to wrap around its target protein and bind to its CaM-binding site with an affinity in the nanomolar range through non-specific van der Waals interactions. The co-location of two EF hands in each globular domain allows Ca^{2+} to bind cooperatively, which ensures that CaM activation occurs over a narrow range of Ca^{2+} concentrations. The affinity of CaM for Ca^{2+} may be profoundly influenced by the presence of particular target proteins (Zielinski, 1998). Calmodulins bind to many different proteins implicated in diverse physiological processes including cation transport (including $[Ca^{2+}]_{cyt}$ homeostasis), cytoskeletal rearrangements and cell division, phytohormone and phospholipid signalling, disease resistance (including the oxidative burst) and stress tolerance (Zielinski, 1998; Reddy, 2001; Snedden and Fromm, 2001; Luan *et al.*, 2002; Reddy *et al.*, 2002). Calmodulins can also regulate gene expression by binding to specific transcription factors (Szymanski *et al.*, 1996; Reddy *et al.*, 2000; Yang and Poovaiah, 2000; Bouché *et al.*, 2002).

Small gene families encode CaM isoforms in plants. Many species possess several CaM genes encoding identical proteins as well as other genes encoding divergent isoforms (Zielinski, 1998; Snedden and Fromm, 2001). It is thought that the presence of genes encoding identical CaMs may reflect a need for diverse tissue-specific, developmental or stress-induced expression, and the presence of genes encoding different CaM isoforms may reflect a requirement for specific interactions with target proteins (Reddy, 2001;

Snedden and Fromm, 2001). Indeed, it has been suggested that particular CaM isoforms transduce specific environmental or developmental signals. Consistent with this hypothesis, it has been shown that environmental challenges rapidly up-regulate the expression of different CaM isoforms. For example, a subset of CaM genes is up-regulated by touch in various plants (Braam *et al.* 1997; Verma and Upadhyaya, 1998; Zielinski, 1998), cold shock and wind stimuli lead to the expression of different CaM isoforms (van der Luit *et al.*, 1999), and specific CaM genes are up-regulated in response to wounding or pathogens (Heo *et al.*, 1999; Yamakawa *et al.*, 2001), auxin or salinity (Botella and Arteca, 1994). Many CaM isoforms show tissue-specific and/or developmentally regulated expression (Gawienowski *et al.* 1993; Takezawa *et al.*, 1995; Yang *et al.*, 1998; Yamakawa *et al.*, 2001; Duval *et al.*, 2002), and CaM isoforms can differentially regulate target enzymes or have contrasting affinities for Ca^{2+} and CaM-binding peptides (Liao *et al.*, 1996; Liu *et al.*, 1998; Reddy *et al.*, 1999; Köhler and Neuhaus, 2000; Lee *et al.*, 2000; Duval *et al.*, 2002; Zielinski, 2002). Calmodulins can also be post-translationally trimethylated, which influences both their stability and physiological activities (Zielinski, 1998). All these properties are consistent with $[\text{Ca}^{2+}]_{\text{cyt}}$ signatures producing unique biochemical and physiological consequences in cells expressing specific CaM isoforms and target proteins. Interestingly, target proteins themselves may have CaM-binding or non-binding isoforms (Snedden and Fromm, 2001), which presumably allows for $[\text{Ca}^{2+}]_{\text{cyt}}$ -dependent and $[\text{Ca}^{2+}]_{\text{cyt}}$ -independent regulatory cascades.

Plants also possess 'CAM-like' proteins. These have between one and six EF hands and a limited homology to CaM (defined arbitrarily as <75% identity with canonical CaM isoforms; Reddy, 2001; Snedden and Fromm, 2001; Luan *et al.*, 2002; Zielinski, 2002). In arabidopsis, they include: CaBP-22 (Ling and Zielinski, 1993), TCH2 and TCH3 (Braam *et al.*, 1997), AtCP1 (Jang *et al.*, 1998), centrins (Cordeiro *et al.*, 1998), NADPH oxidases (AtrbohA–F; Torres *et al.*, 1998), homologues of the rice ABA-inducible EFA27 protein (Frandsen *et al.*, 1996) and Ca^{2+} -binding protein phosphatases such as ABI1 and ABI2 (Leung *et al.*, 1997). These proteins have been implicated in cellular responses to diverse environmental, developmental and pathological challenges.

Calcium-binding proteins: calcineurin B-like proteins

Calcineurin B-like proteins (CBL) possess three EF hands (Luan *et al.*, 2002). In arabidopsis there are at least ten *AtCBL* genes, including *AtSOS3* (*AtCBL4*), which encodes a Ca^{2+} -sensor protein involved in salt tolerance (Liu and Zhu, 1998; Luan *et al.*, 2002; Xiong *et al.*, 2002). Many CBLs have a conserved myristoylation site in their N-termini, which allows membrane association. It has been proposed that myristoylation of CBLs alters their cellular location and intracellular interactions (Luan *et al.*, 2002). It is thought that particular CBLs transduce specific environmental or developmental signals. Consistent with this hypothesis is the induction of *AtCBL1* expression by drought, salinity, cold and wounding (Kudla *et al.*, 1999; Piao *et al.*, 2001)

and the accumulation of *AtCBL1* and *AtCBL2* transcripts in leaves upon illumination (Nozawa *et al.*, 2001). A family of SNF1-like serine/threonine protein kinases (*AtCIPK1* through *AtCIPK25*) has been identified as Ca^{2+} -dependent targets for *AtCBLs* (Shi *et al.*, 1999; Halfter *et al.*, 2000; Albrecht *et al.*, 2001; Y. Guo *et al.*, 2001; Luan *et al.*, 2002). The CIPKs interact with CBLs through a unique 24-amino-acid domain termed the 'NAF domain' (Albrecht *et al.*, 2001) and require divalent-cation cofactors for their activity (Luan *et al.*, 2002). Both *AtCIPK1* and *AtCIPK2* require Mn^{2+} as a cofactor and *AtSOS2* (*AtCIPK24*) requires Mg^{2+} . Each CBL protein may interact with several CIPKs. For example, *AtCBL1* interacts with numerous *AtCIPKs* (Shi *et al.*, 1999) and *AtSOS3* interacts with *AtSOS2* (*AtCIPK24*) and at least seven other *AtCIPKs* (Halfter *et al.*, 2000; Y. Guo *et al.*, 2001). Conversely, certain *AtCIPKs* can interact with several *AtCBLs* (Shi *et al.*, 1999; Kim *et al.*, 2000; Albrecht *et al.*, 2001; Y. Guo *et al.*, 2001). Common interactions between *AtCBLs* and *AtCIPKs* may allow cross-talk between signalling cascades, whereas preferential associations between CBLs and CIPKs are thought to underpin specific signalling cascades. In this context it is noteworthy that the expression of *CIPKs* (in addition to *CBLs*) can be tissue specific and/or regulated by environmental stresses such as cold, drought, salinity, wounding or nutrient starvation (Albrecht *et al.*, 2001; Y. Guo *et al.*, 2001; Kim *et al.*, 2003).

Calcium-binding proteins: calcium-dependent protein kinases

The activity of many protein kinases can respond to $[\text{Ca}^{2+}]_{\text{cyt}}$ signals directly. These can be placed in one of four classes: Ca^{2+} -dependent protein kinases (CDPKs), CDPK-related proteins (CRKs), CaM-dependent protein kinases (CaMKs) and chimeric Ca^{2+} - and CaM-dependent protein kinases (CCaMKs). McAinsh and Hetherington (1998) proposed an interesting model for generating specific physiological responses to $[\text{Ca}^{2+}]_{\text{cyt}}$ perturbations through the action of Ca^{2+} -dependent and Ca^{2+} -independent protein kinases and phosphatases. In this model, specific $[\text{Ca}^{2+}]_{\text{cyt}}$ perturbations influence the degree of phosphorylation of a target protein leading to contrasting or graded responses.

The CDPKs are ubiquitous in plants. There are at least 34 genes encoding CDPKs in the arabidopsis genome (Harmon *et al.*, 2001; S. H. Cheng *et al.*, 2002) and similar numbers in other plant species. They generally have four EF hands at their C-terminus that bind Ca^{2+} to activate their serine/threonine kinase activity. They act as monomers and many may be autoinhibited by autophosphorylation of a pseudo-substrate domain (S. H. Cheng *et al.*, 2002). Different CDPKs have contrasting affinities for Ca^{2+} (Lee *et al.*, 1998) and the binding of Ca^{2+} to some CDPKs is modulated by lipids, interactions with 14-3-3 proteins or phosphorylation (Reddy, 2001; S. H. Cheng *et al.*, 2002; Sanders *et al.*, 2002). No CDPKs appear to be integral membrane proteins, but many are associated with the cytoskeleton, nucleus, plasma membrane and ER (Reddy, 2001; Sanders *et al.*, 2002). At least 24 arabidopsis CDPKs can potentially undergo myristoylation and palmitoylation at their N-

termini, which may facilitate their association with membranes (S. H. Cheng *et al.*, 2002; Xiong *et al.*, 2002).

The CDPKs are capable of converting $[Ca^{2+}]_{cyt}$ signals into biochemical and genetic consequences through the phosphorylation of diverse target proteins including membrane solute transporters (including the Ca^{2+} -ATPase, AtACA2), ion and water channels, NADPH oxidases, enzymes involved in carbon and nitrogen metabolism, cytoskeletal proteins, proteases and DNA-binding proteins (Reddy, 2001; Rudd and Franklin-Tong, 2001; S. H. Cheng *et al.*, 2002; Sanders *et al.*, 2002). They are implicated in pollen development, control of the cell cycle, phytohormone signal transduction, light-regulated gene expression, gravitropism, thigmotropism, nodulation, cold acclimation, salinity tolerance, drought tolerance and responses to pathogens (Sheen, 1996; Saijo *et al.*, 2000; Anil and Sankara Rao, 2001; Reddy, 2001; Romeis *et al.*, 2001; S. H. Cheng *et al.*, 2002; Xiong *et al.*, 2002; Lee *et al.*, 2003). It is thought that the possession of many CDPKs with contrasting Ca^{2+} affinities and target proteins allows plant cells to respond appropriately to specific $[Ca^{2+}]_{cyt}$ perturbations (Anil and Sankara Rao, 2001; S. H. Cheng *et al.*, 2002; Sanders *et al.*, 2002). In various plant species specific CDPKs are induced by cold, drought, salinity, anoxia, mechanical stress, wounding and pathogen elicitors (Urao *et al.*, 1994; Breviarario *et al.*, 1995; Monroy and Dhinsa, 1995; Botella *et al.*, 1996; Tähtiharju *et al.*, 1997; Yoon *et al.*, 1999; Saijo *et al.*, 2000; Anil and Sankara Rao, 2001; Romeis *et al.*, 2001; Chico *et al.*, 2002; Lee *et al.*, 2003). In addition, the activities of CDPKs are affected by post-translational modifications during development (Anil *et al.*, 2000) or in response to environmental challenges such as wounding or pathogens (Romeis *et al.*, 2001).

Other protein kinases responding to $[Ca^{2+}]_{cyt}$ are less well characterized than the CDPKs. There are at least seven CRKs in the arabidopsis genome that are structurally similar to CDPKs, but have degenerate or truncated EF hands that may not be able to bind Ca^{2+} (Reddy, 2001). Orthologues of these are present in many plant species. Several CaMKs have also been cloned from arabidopsis and other plants (Zhang and Lu, 2003). Their kinase activity is activated by CaM-dependent autophosphorylation and their catalytic activity is also modulated by CaM. They are expressed highly in rapidly growing cells and tissues of the root and flower (Zhang and Lu, 2003). Chimeric CCaMKs are expressed in the anthers of several plant species, including lily and tobacco (Liu *et al.*, 1998), but none have been identified in arabidopsis (Zhang and Lu, 2003). The CCaMKs possess a CaM-binding domain and three EF hands. They require only Ca^{2+} for autophosphorylation, but Ca^{2+} and CaM for substrate phosphorylation. Liu *et al.* (1998) demonstrated that different CaM isoforms have contrasting effects on substrate phosphorylation by lily and tobacco CCaMKs, suggesting that these kinases could respond to specific environmental or developmental challenges.

Calcium-binding proteins: proteins without EF hands

Several proteins lacking EF hands are also capable of binding Ca^{2+} (Reddy, 2001; Anil and Sankara Rao, 2001).

For example, the activity of phospholipase D (PLD), which cleaves membrane phospholipids into a soluble head group and phosphatidic acid, is regulated by $[Ca^{2+}]_{cyt}$ through a Ca^{2+} /phospholipid binding-site termed the 'C2 domain' (Wang, 2001). Phospholipase D activity is implicated in cellular responses to ethylene and ABA, α -amylase synthesis in aleurone cells, stomatal closure, pathogen responses, leaf senescence and drought tolerance (Ritchie *et al.*, 2002). Plants possess several PLD isoforms that differ in their affinity for Ca^{2+} and their modulation by phosphoinositides, free fatty acids and lysolipids (Wang, 2001). These biochemical modulators of PLD activity are the substrates or products of phospholipase C, which generates IP_3 and diacylglycerol, phospholipase A_2 and diacylglycerol kinase, both of which are regulated by CaM. It has therefore been suggested that $[Ca^{2+}]_{cyt}$ signalling cascades might coordinate the activities of these diverse enzymes to effect specific responses to contrasting environmental or developmental stimuli (Wang, 2001).

In annexins, Ca^{2+} is bound by the 'endonexin fold', which contains a characteristic GXGT-{38}-(D/E) motif (Delmer and Potikha, 1997). This often appears only in the first quarter of plant annexins, although animal annexins generally possess four such motifs. The binding of Ca^{2+} to annexins enables them to associate with membranes to form cation-channels (Hofmann *et al.*, 2000; White *et al.*, 2002a). In plants, annexins are encoded by small gene families. Seven annexin genes (*AnnAt1-7*) have been identified in arabidopsis (Clark *et al.*, 2001; White *et al.*, 2002a). Most annexin genes are expressed throughout the plant, but annexins are especially abundant in highly secretory cell types, where they are located at the cell periphery and may have a role in membrane fusion, membrane trafficking and/or secretion (Clark *et al.*, 2001). The increased expression of certain annexins upon specific developmental or environmental challenges has linked them with Ca^{2+} signals during root nodulation, pathogen attack, ABA responses, fruit ripening and cold acclimation (White *et al.*, 2002a).

Other Ca^{2+} -binding proteins include calreticulin, calsequestrin, calnexin and BiP, which sequester Ca^{2+} in the ER. These proteins are implicated in Ca^{2+} homeostasis, protein folding and post-translational modifications (Crofts and Denecke, 1998; Michalak *et al.*, 1998). The expression of calreticulin is increased in reproductive tissues. Calreticulin possesses two Ca^{2+} -binding domains. The first is a proline-rich, low-capacity/high-affinity Ca^{2+} -binding domain ($K_d = 1 \mu M$; 1 mol Ca^{2+} mol protein $^{-1}$) that contains a highly conserved stretch of amino acids (KPEDWD). The second is a high-capacity/low-affinity Ca^{2+} -binding domain ($K_d = 2 \text{ mM}$; 25 mol Ca^{2+} mol protein $^{-1}$) comprising acidic amino acid residues (generally glutamate and aspartate). Both calreticulin and BiP, and a Ca^{2+} -binding protein (PCP) expressed in *Brassica* pistils and implicated in pollen-pistil interactions (Furuyama and Dzelzkalns, 1999) also possess high-capacity/low-affinity Ca^{2+} -binding domains. Calnexin possesses a proline-rich low-capacity/high-affinity Ca^{2+} -binding domain.

Calcium and CaM-binding transcription factors

Changes in $[Ca^{2+}]_{cyt}$ may influence nuclear Ca^{2+} activities, but cell nuclei are also capable of initiating autonomous Ca^{2+} signals (van der Luit *et al.*, 1999; Pauly *et al.*, 2001). Perturbations in nuclear Ca^{2+} activities are thought to regulate DNA transcription, the cell cycle during mitosis and meiosis, DNA replication and DNA fragmentation during programmed cell death (Snedden and Fromm, 2001). Signal transduction through Ca^{2+}/CaM has been inferred in several instances (Yang and Poovaiah, 2000; Rudd and Franklin-Tong, 2001; Snedden and Fromm, 2001; Townley and Knight, 2002). It is possible for Ca^{2+}/CaM to interact with target proteins in the cytosol, which subsequently transduce a signal to the nucleus, or with target proteins in the nucleus itself (Snedden and Fromm, 2001). Several CaM isoforms have been located in the nuclei of plant cells. In animals, $[Ca^{2+}]_{cyt}$ signals appear to direct the translocation of CaM into the nucleus and environmental signals have been shown to alter the distribution of petunia CaM53 (Rodríguez-Concepción *et al.*, 1999) and rice OsCaM61 (Dong *et al.*, 2002) between the plasma membrane and the nucleus by influencing their prenylation. Transcription factors are among the target proteins for Ca^{2+}/CaM in plant cell nuclei (Szymanski *et al.*, 1996; Reddy *et al.*, 2000; Yang and Poovaiah, 2000; Bouché *et al.*, 2002; Reddy *et al.*, 2002). Such interactions have been suggested in the transduction of phytohormone signals, phytochrome-responses and acclimation to low temperatures. Interestingly, the expression of some CaM isoforms might be autoregulated through interactions between Ca^{2+}/CaM and transcription factors (Szymanski *et al.*, 1996). It has been suggested that this could supply stoichiometric levels of CaM isoforms for the activation of target proteins and, thereby, provide a mechanism for their long-term or subsequent activation. A CaM-like protein has also been implicated in the suppression of post-transcriptional gene silencing in plants (Anandalakshmi *et al.*, 2000). In addition to Ca^{2+}/CaM signal transduction cascades, CaM-independent CDPKs have also been implicated in the regulation of nuclear gene expression (Patharkar and Cushman, 2000) and a nuclear transcription factor with two EF hands (AtSUB1) has been implicated in transcriptional responses to blue and far-red light (H. Guo *et al.*, 2001). The arabidopsis genome contains two homologues of AtSUB1: AtSUL1 and AtSUL2.

PERSPECTIVES

It has long been known that Ca is an essential element for plants, and that plant species differ in both the amounts of Ca they require and their tolerance of Ca in the rhizosphere. These differences between plant species not only influence the natural flora of calcareous soils but also have consequences for breeding crops to improve the delivery of Ca to the human diet. Recent research in this area has concentrated on elucidating the physiology and biochemistry underpinning contrasting Ca phenotypes and in developing a phylogenetic framework to describe the variation in $[Ca]_{shoot}$ within the angiosperms. This work will be used to

inform the modelling of responses of plant communities to environmental change, of nutrient and contaminant partitioning within an ecosystem, and of the delivery of Ca to the food chain.

More recently, research on Ca in plants has been focused at the cellular level. This is presumably a consequence of the realization, some two decades ago, that $[Ca^{2+}]_{cyt}$ was an obligate intracellular messenger coordinating the cellular responses to numerous developmental cues and environmental challenges. Since then, biochemists have characterized the Ca^{2+} -ATPases and H^+/Ca^{2+} -antiporters required to maintain submicromolar $[Ca^{2+}]_{cyt}$ in a resting cell, and electrophysiologists have characterized the Ca^{2+} -permeable channels that raise $[Ca^{2+}]_{cyt}$ to initiate $[Ca^{2+}]_{cyt}$ signals. Genes encoding these transport proteins have been identified, and their spatial and temporal expression patterns, subcellular locations, functional properties and physiological roles are being studied using a variety of biochemical, physiological, molecular biological and genetic techniques. In parallel, the origin and specificity of $[Ca^{2+}]_{cyt}$ signals are being addressed. In particular, the hypothesis that each developmental cue or environmental challenge produces a unique $[Ca^{2+}]_{cyt}$ signature to elicit specific cellular responses is being tested using cell-specific targeting of transgenic aequorin (Knight *et al.*, 1991) and cameleon (Allen *et al.*, 1999) Ca^{2+} -reporters in combination with single-cell transcript profiling (Karrer *et al.*, 1995; Brandt *et al.*, 2002). Researchers are also identifying the cellular $[Ca^{2+}]_{cyt}$ -sensors that allow plant cells to respond appropriately to $[Ca^{2+}]_{cyt}$ signals, and elucidating their biochemical properties and interactions with target proteins. The involvement of specific $[Ca^{2+}]_{cyt}$ -sensors in particular physiological responses is indicated by their diverse tissue expression patterns and by their contrasting changes in expression in response to developmental or environmental stimuli. This hypothesis will be tested through the analysis of transgenic plants mis-expressing $[Ca^{2+}]_{cyt}$ -sensors.

Undoubtedly, the application of functional genomics will provide further insights to the biology of Ca in plants. For example, oligonucleotide microarrays might be used to identify the genetic consequences of acclimation to low or high $[Ca^{2+}]_{ext}$. This will provide a unique insight into the physiology of Ca accumulation. Genetic responses to changes in $[Ca^{2+}]_{ext}$ might include the differential expression of transport proteins, of enzymes in the biochemical pathways containing compounds that chelate Ca, or of transcriptional cascades that lead to the modification of plant anatomy and/or morphology. These responses could not be predicted *a priori*. In parallel, genes that impact on Ca accumulation in the shoot might be identified through the resolution of quantitative trait loci (QTL) detected using mapping populations that show variation in their ability to accumulate Ca in the shoot. These are available for several plant species. Information from both microarray and QTL analyses could be used to formulate hypotheses on the impact of specific genes on $[Ca]_{shoot}$, which might be tested by investigating the phenotype of transgenic plants mis-expressing candidate genes. Such approaches could ultimately lead to the development of crops that accumulate less of contaminants, such as radiocesium, or deliver more Ca

to the food chain. The challenge of the immediate future will be to integrate the massive data sets arising from plant 'omic' technologies into a cohesive conceptual framework for Ca in plants that embraces both its roles in biochemistry and cell signalling.

ACKNOWLEDGEMENTS

We thank Graham Seymour (HRI) for comments on cell wall composition, Lim Ho (HRI) for his photographs of horticultural disorders, Marc Knight (Oxford) for the overview of $[Ca^{2+}]_{cyt}$ signals he presented at 'Calcium 2002' at HRI-Wellesbourne, and Tim Flowers (Sussex) for his editorial encouragement. The research in our laboratories is supported by the Biotechnology and Biological Sciences Research Council (UK) and by the Department for Environment, Food and Rural Affairs (UK).

LITERATURE CITED

- Ache P, Becker D, Ivashikina N, Dietrich P, Roelfsema MRG, Hedrich R. 2000. GORK, a delayed outward rectifier expressed in guard cells of *Arabidopsis thaliana*, is a K^+ -selective, K^+ -sensing ion channel. *FEBS Letters* 486: 93–98.
- Albrecht V, Ritz O, Linder S, Harter K, Kudla J. 2001. The NAF domain defines a novel protein–protein interaction module conserved in Ca^{2+} -regulated kinases. *EMBO Journal* 20: 1051–1063.
- Allen GJ, Sanders D. 1997. Vacuolar ion channels in higher plants. *Advances in Botanical Research* 25: 217–252.
- Allen GJ, Chu SP, Harrington CL, Schumacher K, Hoffmann T, Tang YY, Grill E, Schroeder JI. 2001. A defined range of guard cell calcium oscillation parameters encodes stomatal movements. *Nature* 411: 1053–1057.
- Allen GJ, Chu SP, Schumacher K, Shimazaki CT, Vafeados D, Kemper A, Hawke SD, Tallman G, Tsien RY, Harper JF et al. 2000. Alteration of stimulus specific guard cell calcium oscillations and stomatal closing in *Arabidopsis det3* mutant. *Science* 289: 2338–2342.
- Allen GJ, Kwak JM, Chu SP, Llopis J, Tsien RY, Harper JF, Schroeder JI. 1999. Cameleon calcium indicator reports cytoplasmic calcium dynamics in *Arabidopsis* guard cells. *Plant Journal* 19: 735–747.
- Anandalakshmi R, Marathe R, Ge X, Herr JM, Mau C, Mallory A, Pruss G, Bowman L, Vance VB. 2000. A calmodulin-related protein that suppresses posttranscriptional gene silencing in plants. *Science* 290: 142–144.
- Anil VS, Harmon AC, Sankara Rao K. 2000. Spatio-temporal accumulation and activity of calcium-dependent protein kinases during embryogenesis, seed development, and germination in sandalwood. *Plant Physiology* 122: 1035–1043.
- Anil VS, Sankara Rao K. 2001. Calcium-mediated signal transduction in plants: a perspective on the role of Ca^{2+} and CDPKs during early plant development. *Journal of Plant Physiology* 158: 1237–1256.
- Antoine AF, Dumas C, Faure J-E, Feijó JA, Rougier M. 2001. Egg activation in flowering plants. *Sexual Plant Reproduction* 14: 21–26.
- Asher CJ, Ozanne PG. 1961. The cation exchange capacity of plant roots and its relationship to the uptake of insoluble nutrients. *Australian Journal of Agricultural Research* 12: 755–766.
- Axelsen KB, Palmgren MG. 2001. Inventory of the superfamily of P-type ion pumps in *Arabidopsis*. *Plant Physiology* 126: 696–706.
- Ayling SM, Clarkson DT. 1996. The cytoplasmic streaming response of tomato root hairs to auxin: the role of calcium. *Australian Journal of Plant Physiology* 23: 699–708.
- Batley NH, James NC, Greenland AJ, Brownlee C. 1999. Exocytosis and endocytosis. *Plant Cell* 11: 643–659.
- Baum G, Long JC, Jenkins GI, Trewavas AJ. 1999. Stimulation of the blue light phototropic receptor NPH1 causes a transient increase in cytosolic Ca^{2+} . *Proceedings of the National Academy of Sciences of the USA* 96: 13554–13559.
- Bekreij C, Janse J, Vangoor BJ, Vandoesburg JDJ. 1992. The incidence of calcium-oxalate crystals in fruit walls of tomato *Lycopersicon esculentum* Mill. as affected by humidity, phosphate and calcium supply. *Journal of Horticultural Science* 67: 45–50.
- Bibikova TN, Blancaflor EB, Gilroy S. 1999. Microtubules regulate tip growth and orientation in root hairs of *Arabidopsis thaliana*. *Plant Journal* 17: 657–665.
- Blackford S, Rea PA, Sanders D. 1990. Voltage sensitivity of H^+/Ca^{2+} antiport in higher plant tonoplast suggests a role in vacuolar calcium accumulation. *Journal of Biological Chemistry* 265: 9617–9620.
- Blatt MR. 2000a. Cellular signaling and volume control in stomatal movements in plants. *Annual Review of Cell and Developmental Biology* 16: 221–241.
- Blatt MR. 2000b. Ca^{2+} signalling and control of guard-cell volume in stomatal movements. *Current Opinion in Plant Biology* 3: 196–204.
- Blume B, Nürnberger T, Nass N, Scheel D. 2000. Receptor-mediated increase in cytoplasmic free calcium required for activation of pathogen defense in parsley. *Plant Cell* 12: 1425–1440.
- Blumwald E, Aharon GS, Lam BC-H. 1998. Early signal transduction pathways in plant-pathogen interactions. *Trends in Plant Science* 3: 342–346.
- Botella JR, Arteca RN. 1994. Differential expression of two calmodulin genes in response to physical and chemical stimuli. *Plant Molecular Biology* 24: 757–766.
- Botella JR, Arteca JM, Somodevilla M, Arteca RN. 1996. Calcium-dependent protein kinase gene expression in response to physical and chemical stimuli in mungbean (*Vigna radiata*). *Plant Molecular Biology* 30: 1129–1137.
- Bouché N, Scharlat A, Snedden W, Bouchez D, Fromm H. 2002. A novel family of calmodulin-binding transcription activators in multicellular organisms. *Journal of Biological Chemistry* 277: 21851–21861.
- Bowler C, Fluhr R. 2000. The role of calcium and activated oxygens as signals for controlling cross-tolerance. *Trends in Plant Science* 5: 241–246.
- Braam J, Sistrunk ML, Polisensky DH, Xu W, Purugganan MM, Antosiewicz DM, Campbell P, Johnson KA. 1997. Plant responses to environmental stress: regulation and functions of the *Arabidopsis* TCH genes. *Planta* 203: S35–S41.
- Brandt S, Kloska S, Altmann T, Kehr J. 2002. Using array hybridization to monitor gene expression at the single cell level. *Journal of Experimental Botany* 53: 2315–2323.
- Breviaro D, Morello L, Giani S. 1995. Molecular cloning of two novel rice cDNA sequences encoding putative calcium-dependent protein kinases. *Plant Molecular Biology* 27: 953–967.
- Broadley MR, Bowen HC, Cotterill HL, Hammond JP, Meacham MC, Mead A, White PJ. 2003a. Variation in the shoot calcium content of angiosperms. *Journal of Experimental Botany* 54: 1431–1446.
- Broadley MR, Bowen HC, Cotterill HL, Hammond JP, Meacham MC, Mead A, White PJ. 2003b. Quantifying the phylogenetic variation in the shoot mineral content of angiosperms. *Journal of Experimental Botany* 54: in press.
- Broadley MR, Willey NJ, Wilkins JC, Baker AJM, Mead A, White PJ. 2001. Phylogenetic variation in heavy metal accumulation in angiosperms. *New Phytologist* 152: 9–27.
- Bush DS. 1995. Calcium regulation in plant cells and its role in signaling. *Annual Review of Plant Physiology and Plant Molecular Biology* 46: 95–122.
- Caddick LR, Rudall PJ, Wilkin P, Hedderson TAJ, Chase MW. 2002. Phylogenetics of Dioscoreales based on combined analyses of morphological and molecular data. *Botanical Journal of the Linnean Society* 138: 123–144.
- Camacho L, Malhó R. 2003. Endo/exocytosis in the pollen tube apex is differentially regulated by Ca^{2+} and GTPases. *Journal of Experimental Botany* 54: 83–92.
- Campbell AK, Trewavas AJ, Knight MR. 1996. Calcium imaging shows differential sensitivity to cooling and communication in luminous transgenic plants. *Cell Calcium* 19: 211–218.
- Cárdenas L, Holdaway-Clarke TL, Sánchez F, Quinto C, Feijó JA, Kunkel JG, Hepler PK. 2000. Ion changes in legume root hairs responding to Nod factors. *Plant Physiology* 123: 443–451.

- Cessna SG, Low PS. 2001. Activation of the oxidative burst in aequorin-transformed *Nicotiana tabacum* cells is mediated by protein kinase- and anion channel-dependent release of Ca^{2+} from internal stores. *Planta* **214**: 126–134.
- Cessna SG, Messerli MA, Robinson KR, Low PS. 2001. Measurement of stress-induced Ca^{2+} pulses in single aequorin-transformed tobacco cells. *Cell Calcium* **30**: 151–156.
- Cheng N, Pitman JK, Shigaki T, Hirschi KD. 2002. Characterization of CAX4, an Arabidopsis H^+ /cation antiporter. *Plant Physiology* **128**: 1245–1254.
- Cheng N-H, Pitman JK, Barkla BJ, Shigaki T, Hirschi KD. 2003. The Arabidopsis *cax1* mutant exhibits impaired ion homeostasis, development, and hormonal responses and reveals interplay among vacuolar transporters. *Plant Cell* **15**: 347–364.
- Cheng S-H, Willmann MR, Chen H-C, Sheen J. 2002. Calcium signaling through protein kinases. The Arabidopsis calcium-dependent protein kinase gene family. *Plant Physiology* **129**: 469–485.
- Chico JM, Raíces M, Téllez-Iñón MT, Ulloa RM. 2002. A calcium-dependent protein kinase is systemically induced upon wounding in tomato plants. *Plant Physiology* **128**: 256–270.
- Clapham DE. 1995. Calcium signaling. *Cell* **80**: 259–268.
- Clark GB, Dauwalder M, Roux SJ. 1998. Immunological and biochemical evidence for nuclear localization of annexin in peas. *Plant Physiology and Biochemistry* **36**: 621–627.
- Clark GB, Sessions A, Eastburn DJ, Roux SJ. 2001. Differential expression of members of the annexin multigene family in *Arabidopsis*. *Plant Physiology* **126**: 1072–1084.
- Clarkson DT. 1984. Calcium transport between tissues and its distribution in the plant. *Plant, Cell and Environment* **7**: 449–456.
- Clarkson DT. 1993. Roots and the delivery of solutes to the xylem. *Philosophical Transactions of the Royal Society of London Series B* **341**: 5–17.
- Clayton H, Knight MR, Knight H, McAinsh MR, Hetherington AM. 1999. Dissection of the ozone-induced calcium signature. *Plant Journal* **17**: 575–579.
- Clemens S, Antosiewicz DM, Ward JM, Schachtman DP, Schroeder JI. 1998. The plant cDNA *LCT1* mediates the uptake of calcium and cadmium in yeast. *Proceedings of the National Academy of Sciences of the USA* **95**: 12043–12048.
- Cordeiro MCR, Piqueras R, de Oliveira DE, Castresana C. 1998. Characterization of early induced genes in *Arabidopsis thaliana* responding to bacterial inoculation: identification of centrin and of a novel protein with two regions related to kinase domains. *FEBS Letters* **434**: 387–393.
- Cramer GR, Jones RL. 1996. Osmotic stress and abscisic acid reduce cytosolic calcium activities in roots of *Arabidopsis thaliana*. *Plant, Cell and Environment* **19**: 1291–1298.
- Crofts AJ, Denecke J. 1998. Calreticulin and calnexin in plants. *Trends in Plant Science* **3**: 396–399.
- Crooke WM, Knight AH. 1962. An evaluation of published data on the mineral composition of plants in the light of the cation-exchange capacities of their roots. *Soil Science* **93**: 365–373.
- Davenport RJ, Tester M. 2000. A weakly voltage-dependent nonselective cation channel mediates toxic sodium influx in wheat. *Plant Physiology* **122**: 823–834.
- De Boer AH. 1999. Potassium translocation into the root xylem. *Plant Biology* **1**: 36–45.
- de Carvalho-Niebel F, Timmers ACJ, Chabaud M, Defaux-Petras A, Barker DG. 2002. The Nod factor-elicited annexin MtAnn1 is preferentially localised at the nuclear periphery in symbiotically activated root tissues of *Medicago truncatula*. *Plant Journal* **32**: 343–352.
- Delmer DP, Potikha TS. 1997. Structure and functions of annexins in plants. *Cellular and Molecular Life Sciences* **53**: 546–553.
- Demidchik VV, Tester MA. 2002. Sodium fluxes through non-selective cation channels in the plasma membrane of protoplasts from *Arabidopsis* roots. *Plant Physiology* **128**: 379–387.
- Demidchik V, Bowen HC, Maathuis FJM, Shabala SN, Tester MA, White PJ, Davies JM. 2002a. *Arabidopsis thaliana* root non-selective cation channels mediate calcium uptake and are involved in growth. *Plant Journal* **32**: 799–808.
- Demidchik VV, Davenport RJ, Tester MA. 2002b. Non-selective cation channels in plants. *Annual Review of Plant Biology* **53**: 67–107.
- Denis V, Cyert MS. 2002. Internal Ca^{2+} release in yeast is triggered by hypertonic shock and mediated by a TRP channel homologue. *Journal of Cell Biology* **156**: 29–34.
- DeSilva DLR, Hetherington AM, Mansfield TA. 1996. Where does all the calcium go? Evidence of an important regulatory role for trichomes in two calcicoles. *Plant, Cell and Environment* **19**: 880–886.
- DeSilva DLR, Hetherington AM, Mansfield TA. 1998. The regulation of apoplastic calcium in relation to intracellular signalling in stomatal guard cells. *Zeitschrift für Pflanzenernährung und Bodenkunde* **161**: 533–539.
- DeWald DB, Torabinejad J, Jones CA, Shope JC, Cangelosi AR, Thompson JE, Prestwich GD, Hama H. 2001. Rapid accumulation of phosphatidylinositol 4,5-bisphosphate and inositol 1,4,5-trisphosphate correlates with calcium mobilization in salt-stressed *Arabidopsis*. *Plant Physiology* **126**: 759–769.
- Dolmetsch RE, Lewis RS, Goodnow CC, Healy JI. 1997. Differential activation of transcription factors induced by Ca^{2+} response amplitude and duration. *Nature* **386**: 855–858.
- Dolmetsch RE, Xu K, Lewis RS. 1998. Calcium oscillations increase the efficiency and specificity of gene expression. *Nature* **392**: 933–936.
- Dong A, Xin H, Yu Y, Sun C, Cao K, Shen W-H. 2002. The subcellular localization of an unusual rice calmodulin isoform, OsCaM61, depends on its prenylation state. *Plant Molecular Biology* **48**: 203–210.
- Drøbak BK, Watkins PAC. 2000. Inositol(1,4,5)trisphosphate production in plant cells: an early response to salinity and hyperosmotic stress. *FEBS Letters* **481**: 240–244.
- Durner J, Wendehenne D, Klessig DF. 1998. Defense gene induction in tobacco by nitric oxide, cyclic GMP, and cyclic ADP-ribose. *Proceedings of the National Academy of Sciences of the USA* **95**: 10328–10333.
- Duval FD, Renard M, Jaquinod M, Biou V, Montrichard F, Macherel D. 2002. Differential expression and functional analysis of three calmodulin isoforms in germinating pea (*Pisum sativum* L.) seeds. *Plant Journal* **32**: 481–493.
- Evans DE, Williams LE. 1998. P-type calcium ATPases in higher plants – biochemical, molecular and functional properties. *Biochimica et Biophysica Acta* **1376**: 1–25.
- Evans NH, McAinsh MR, Hetherington AM. 2001. Calcium oscillations in higher plants. *Current Opinion in Plant Biology* **4**: 415–420.
- Fasano JM, Massa GD, Gilroy S. 2002. Ionic signaling in plant responses to gravity and touch. *Journal of Plant Growth Regulation* **21**: 71–88.
- Fellbrich G, Blume B, Brunner F, Hirt H, Kroj T, Ligterink W, Romanski A, Nürnberger T. 2000. *Phytophthora parasitica* elicitor-induced reactions in cells of *Petroselinum crispum*. *Plant and Cell Physiology* **41**: 692–701.
- Felle H. 1988. Auxin causes oscillations of cytosolic free calcium and pH in *Zea mays* coleoptiles. *Planta* **174**: 495–499.
- Flowers TJ, Yeo AR. 1992. *Solute transport in plants*. London: Blackie Academic and Professional.
- Foreman J, Demidchik V, Bothwell JHF, Mylona P, Miedema H, Torres MA, Linstead P, Costa S, Brownlee C, Jones JDG *et al.* 2003. Reactive oxygen species produced by NADPH oxidase regulate plant cell growth. *Nature* **422**: 442–446.
- Franceschi VR, Horner HT. 1980. Calcium oxalate crystals in plants. *Botanical Reviews* **46**: 361–427.
- Frandsen G, Müller-Uri F, Nielsen M, Mundy J, Skriver K. 1996. Novel plant Ca^{2+} -binding protein expressed in response to abscisic acid and osmotic stress. *Journal of Biological Chemistry* **271**: 343–348.
- Franklin-Tong VE, Holdaway-Clarke TL, Straatman KR, Kunkel JG, Hepler PK. 2002. Involvement of extracellular calcium influx in the self-incompatibility response of *Papaver rhoeas*. *Plant Journal* **29**: 333–345.
- Fréjat A, Anstett A, Lemaire F. 1967. Capacité d'échange de cations des systèmes racinaires et des sols, et leurs relations avec l'alimentation minérale. *Annales Agronomique* **18**: 31–64.
- Frohnmeier H, Loyall L, Blatt MR, Grabov A. 1999. Millisecond UV-B irradiation evokes prolonged elevation of cytosolic-free Ca^{2+} and

- stimulates gene expression in transgenic parsley cell cultures. *Plant Journal* **20**: 109–117.
- Furuichi T, Cunningham KW, Muto S. 2001.** A putative two pore channel AtTPC1 mediates Ca^{2+} flux in Arabidopsis leaf cells. *Plant and Cell Physiology* **42**: 900–905.
- Furuyama T, Dzelkalns VA. 1999.** A novel calcium-binding protein is expressed in *Brassica* pistils and anthers late in flower development. *Plant Molecular Biology* **39**: 729–737.
- Garciadeblas B, Benito B, Rodríguez-Navarro A. 2001.** Plant cells express several stress calcium ATPases but apparently no sodium ATPase. *Plant and Soil* **235**: 181–192.
- Gawienowski MC, Szymanski D, Perera IY, Zielinski RE. 1993.** Calmodulin isoforms in *Arabidopsis* encoded by multiple divergent mRNAs. *Plant Molecular Biology* **22**: 215–225.
- Gaymard F, Pilot G, Lacombe B, Bouchez D, Bruneau D, Boucherez J, Michaux-Ferrière N, Thibaud J-B, Sentenac H. 1998.** Identification and disruption of a plant shaker-like outward channel involved in K^+ release into the xylem sap. *Cell* **94**: 647–655.
- Geisler M, Axelsen KB, Harper JF, Palmgren MG. 2000.** Molecular aspects of higher plant P-type Ca^{2+} -ATPases. *Biochimica et Biophysica Acta* **1465**: 52–78.
- Gilroy S, Trewavas A. 2001.** Signal processing and transduction in plant cells: the end of the beginning? *Nature Reviews Molecular Cell Biology* **2**: 307–314.
- Gong M, van der Luit AH, Knight MR, Trewavas AJ. 1998.** Heat-shock-induced changes in intracellular Ca^{2+} level in tobacco seedlings in relation to thermotolerance. *Plant Physiology* **116**: 429–437.
- Grabov A, Blatt MR. 1998.** Membrane voltage initiates Ca^{2+} waves and potentiates Ca^{2+} increases with abscisic acid in stomatal guard cells. *Proceedings of the National Academy of Sciences of the USA* **95**: 4778–4783.
- Graham RD, Welch RM, Bouis HE. 2001.** Addressing micronutrient malnutrition through enhancing the nutritional quality of staple foods: principles, perspectives and knowledge gaps. *Advances in Agronomy* **70**: 77–142.
- Grant M, Brown I, Adams S, Knight M, Ainslie A, Mansfield J. 2000.** The *RPM1* plant disease resistance gene facilitates a rapid and sustained increase in cytosolic calcium that is necessary for the oxidative burst and hypersensitive cell death. *Plant Journal* **23**: 441–450.
- Grime JP. 2001.** *Plant strategies, vegetation processes, and ecosystem properties*, 2nd edn. Chichester, UK: Wiley.
- Grygorczyk C, Grygorczyk R. 1998.** A Ca^{2+} - and voltage-dependent cation channel in the nuclear envelope of red beet. *Biochimica et Biophysica Acta* **1375**: 117–130.
- Guo H, Mockler T, Duong H, Lin C. 2001.** SUB1, an *Arabidopsis* Ca^{2+} -binding protein involved in cryptochrome and phytochrome coaction. *Science* **291**: 487–490.
- Guo Y, Halfter U, Ishitani M, Zhu J-K. 2001.** Molecular characterization of functional domains in the protein kinase SOS2 that is required for plant salt tolerance. *Plant Cell* **13**: 1383–1400.
- Haley A, Russell AJ, Wood N, Allan AC, Knight M, Campbell AK, Trewavas AJ. 1995.** Effects of mechanical signaling on plant cell cytosolic calcium. *Proceedings of the National Academy of Sciences of the USA* **92**: 4124–4128.
- Halfter U, Ishitani M, Zhu J-K. 2000.** The *Arabidopsis* SOS2 protein kinase physically interacts with and is activated by the calcium-binding protein SOS3. *Proceedings of the National Academy of Sciences of the USA* **97**: 3735–3740.
- Halperin SJ, Gilroy S, Lynch JP. 2003.** Sodium chloride reduces growth and cytosolic calcium, but does not affect cytosolic pH, in root hairs of *Arabidopsis thaliana* L. *Journal of Experimental Botany* **54**: 1269–1280.
- Hamilton DWA, Hills A, Blatt MR. 2001.** Extracellular Ba^{2+} and voltage interact to gate Ca^{2+} channels at the plasma membrane of stomatal guard cells. *FEBS Letters* **491**: 99–103.
- Hamilton DWA, Hills A, Köhler B, Blatt MR. 2000.** Ca^{2+} channels at the plasma membrane of stomatal guard cells are activated by hyperpolarization and abscisic acid. *Proceedings of the National Academy of Sciences of the USA* **97**: 4967–4972.
- Harmon AC, Gribskov M, Gubrium E, Harper JF. 2001.** The CDPK superfamily of protein kinases. *New Phytologist* **151**: 175–183.
- Harper JF. 2001.** Dissecting calcium oscillators in plant cells. *Trends in Plant Science* **6**: 395–397.
- Haynes RJ. 1980.** Ion exchange properties of roots and ionic interactions within the root apoplasm: their role in ion accumulation by plants. *Botanical Review* **46**: 75–99.
- Heintze SG. 1961.** Studies on cation-exchange capacities of roots. *Plant and Soil* **13**: 365–383.
- Heo WD, Lee SH, Kim MC, Kim JC, Chung WS, Chun HJ, Lee KJ, Park CY, Park HC, Choi JY, Cho MJ. 1999.** Involvement of specific calmodulin isoforms in salicylic acid-independent activation of plant disease resistance responses. *Proceedings of the National Academy of Sciences of the USA* **96**: 766–771.
- Hirschi K. 2001.** Vacuolar $\text{H}^+/\text{Ca}^{2+}$ transport: who's directing the traffic? *Trends in Plant Science* **6**: 100–104.
- Hofmann A, Proust J, Dorowski A, Schantz R, Huber R. 2000.** Annexin 24 from *Capsicum annum*. X-ray structure and biochemical characterization. *Journal of Biological Chemistry* **275**: 8072–8082.
- Holdaway-Clarke TL, Feijó JA, Hackett GR, Kunkel JG, Hepler PK. 1997.** Pollen tube growth and the intracellular cytosolic calcium gradient oscillate in phase while extracellular calcium influx is delayed. *Plant Cell* **9**: 1999–2010.
- Huang F-Y, Philosoph-Hadas S, Meir S, Callahan DA, Sabato R, Zelcer A, Hepler PK. 1997.** Increases in cytosolic Ca^{2+} in parsley mesophyll cells correlate with leaf senescence. *Plant Physiology* **115**: 51–60.
- Hwang I, Sze H, Harper JF. 2000.** A calcium-dependent protein kinase can inhibit a calmodulin-stimulated Ca^{2+} pump (ACA2) located in the endoplasmic reticulum of *Arabidopsis*. *Proceedings of the National Academy of Sciences of the USA* **97**: 6224–6229.
- Jang HJ, Pih KT, Kang SG, Lim JH, Jin JB, Piao HL, Hwang I. 1998.** Molecular cloning of a novel Ca^{2+} -binding protein that is induced by NaCl stress. *Plant Membrane Biology* **37**: 839–847.
- Jarvis MC, Forsyth W, Duncan HJ. 1988.** A survey of the pectic content of nonlignified monocot cell walls. *Plant Physiology* **88**: 309–314.
- Jefferies RL, Willis AJ. 1964.** Studies on the calcicole-calcifuge habit. II. The influence of calcium on the growth and establishment of four species in soil and sand cultures. *Journal of Ecology* **52**: 691–707.
- Johnson CH, Knight MR, Kondo T, Masson P, Sedbrook J, Haley A, Trewavas A. 1995.** Circadian oscillations of cytosolic and chloroplastic free calcium in plants. *Science* **269**: 1863–1865.
- Karley AJ, Leigh RA, Sanders D. 2000.** Where do all the ions go? The cellular basis of differential ion accumulation in leaf cells. *Trends in Plant Science* **5**: 465–470.
- Karrer EE, Lincoln JE, Hogenhout S, Bennett AB, Bostock RM, Martineau B, Lucas WJ, Gilchrist DG, Alexander D. 1995.** *In situ* isolation of mRNA from individual plant cells: creation of cell-specific cDNA libraries. *Proceedings of the National Academy of Sciences of the USA* **92**: 3814–3818.
- Kawano T, Muto S. 2000.** Mechanism of peroxidase actions for salicylic acid-induced generation of active oxygen species and an increase in cytosolic calcium in tobacco cell suspension culture. *Journal of Experimental Botany* **51**: 685–693.
- Kiegle E, Gilligham M, Haseloff J, Tester M. 2000a.** Hyperpolarisation-activated calcium currents found only in cells from the elongation zone of *Arabidopsis thaliana* roots. *Plant Journal* **21**: 225–229.
- Kiegle E, Moore CA, Haseloff J, Tester MA, Knight MR. 2000b.** Cell-type-specific calcium responses to drought, salt and cold in the *Arabidopsis* root. *Plant Journal* **23**: 267–278.
- Kim HY, Coté GG, Crain RC. 1996.** Inositol 1,4,5-trisphosphate may mediate closure of K^+ channels by light and darkness in *Samanea saman* motor cells. *Planta* **198**: 279–287.
- Kim K-N, Cheong YH, Grant JJ, Pandey GK, Luan S. 2003.** CIPK3, a calcium sensor-associated protein kinase that regulates abscisic acid and cold signal transduction in *Arabidopsis*. *Plant Cell* **18**: 411–423.
- Kim K-N, Cheong YH, Gupta R, Luan S. 2000.** Interaction specificity of *Arabidopsis* calcineurin B-like calcium sensors and their target kinases. *Plant Physiology* **124**: 1844–1853.
- Kinzel H. 1982.** *Pflanzenökologie und Mineralstoffwechsel*. Stuttgart, Germany: Ulmer.
- Kinzel H, Lechner I. 1992.** The specific mineral metabolism of selected plant species and its ecological implications. *Botanica Acta* **105**: 355–361.
- Klessig DF, Durner J, Noad R, Navarre DA, Wendehenne D, Kumar**

- D, Zhou JM, Shah J, Zhang S, Kachroo P *et al.* 2000. Nitric oxide and salicylic acid signaling in plant defense. *Proceedings of the National Academy of Sciences of the USA* 97: 8849–8855.
- Klüsener B, Weiler EW. 1999. A calcium-selective channel from root-tip endomembranes of garden cress. *Plant Physiology* 119: 1399–1405.
- Klüsener B, Boheim G, Liß H, Engelberth J, Weiler EW. 1995. Gadolinium-sensitive, voltage-dependent calcium release channels in the endoplasmic reticulum of a higher plant mechanoreceptor organ. *EMBO Journal* 14: 2708–2714.
- Klüsener B, Young JJ, Murata Y, Allen GJ, Mori IC, Hugouvieux V, Schroeder JI. 2002. Convergence of calcium signaling pathways of pathogenic elicitors and abscisic acid in Arabidopsis guard cells. *Plant Physiology* 130: 2152–2163.
- Knight H. 2000. Calcium signaling during abiotic stress in plants. *International Review of Cytology* 195: 269–324.
- Knight H, Knight MR. 2000. Imaging spatial and cellular characteristics of low temperature calcium signature after cold acclimation in Arabidopsis. *Journal of Experimental Botany* 51: 1679–1686.
- Knight H, Brandt S, Knight MR. 1998. A history of stress alters drought calcium signalling pathways in Arabidopsis. *Plant Journal* 16: 681–687.
- Knight H, Trewavas AJ, Knight MR. 1996. Cold calcium signaling in Arabidopsis involves two cellular pools and a change in calcium signature after acclimation. *Plant Cell* 8: 489–503.
- Knight H, Trewavas AJ, Knight MR. 1997. Calcium signalling in Arabidopsis thaliana responding to drought and salinity. *Plant Journal* 12: 1067–1078.
- Knight MR, Campbell AK, Smith SM, Trewavas AJ. 1991. Transgenic plant aequorin reports the effects of touch and cold-shock and elicitors on cytoplasmic calcium. *Nature* 352: 524–526.
- Knight MR, Read ND, Campbell AK, Trewavas AJ. 1993. Imaging calcium dynamics in living plants using semisynthetic recombinant aequorins. *Journal of Cell Biology* 121: 83–90.
- Knight MR, Smith SM, Trewavas AJ. 1992. Wind-induced plant motion immediately increases cytosolic calcium. *Proceedings of the National Academy of Sciences of the USA* 89: 4967–4971.
- Köhler B, Blatt MR. 2002. Protein phosphorylation activates the guard cell Ca²⁺ channel and is a prerequisite for gating by abscisic acid. *Plant Journal* 32: 185–194.
- Köhler B, Hills A, Blatt MR. 2003. Control of guard cell ion channels by hydrogen peroxide and abscisic acid indicates their action through alternate signaling pathways. *Plant Physiology* 131: 385–388.
- Köhler C, Neuhaus D. 2000. Characterization of calmodulin binding to cyclic nucleotide-gated ion channels from Arabidopsis thaliana. *FEBS Letters* 471: 133–136.
- Kovács I, Ayaydin F, Oberschall A, Ipacs I, Bottka S, Pongor S, Dudits D, Tóth EC. 1998. Immunolocalization of a novel annexin-like protein encoded by a stress and abscisic acid responsive gene in alfalfa. *Plant Journal* 15: 185–187.
- Kudla J, Xu Q, Harter K, Gruissem W, Luan S. 1999. Genes for calcineurin B-like proteins in Arabidopsis are differentially regulated by stress signals. *Proceedings of the National Academy of Sciences of the USA* 96: 4718–4723.
- Kuo-Huang L-L, Sheue C-R, Yang Y-P, Chiang S-HT. 1994. Calcium oxalate crystals in some aquatic angiosperms of Taiwan. *Botanical Bulletin of Academia Sinica* 35: 179–188.
- Leckie CP, McAinsh MR, Allen GJ, Sanders D, Hetherington AM. 1998. Abscisic acid-induced stomatal closure mediated by cyclic ADP-ribose. *Proceedings of the National Academy of Sciences of the USA* 95: 15837–15842.
- Lecourieux D, Mazars C, Pauly N, Ranjeva R, Pugin A. 2002. Analysis and effects of cytosolic free calcium increases in response to elicitors in Nicotiana glauca cells. *Plant Cell* 14: 2627–2641.
- Lee JA. 1999. The calcicole-calcifuge problem revisited. *Advances in Botanical Research* 29: 1–30.
- Lee JY, Yoo BC, Harmon AC. 1998. Kinetic and calcium-binding properties of three calcium-dependent protein kinase isoenzymes from soybean. *Biochemistry* 37: 6801–6809.
- Lee SH, Johnson JD, Walsh MP, Van Lierop JE, Sutherland C, Xu A, Snedden WA, Kosk-Kosicka D, Fromm H, Narayanan N, Cho MJ. 2000. Differential regulation of Ca²⁺/calmodulin-dependent enzymes by plant calmodulin isoforms and free Ca²⁺ concentration. *Biochemical Journal* 350: 299–306.
- Lee SS, Cho HS, Yoon GM, Ahn J-W, Kim H-H, Pai H-S. 2003. Interaction of NiCDPK1 calcium-dependent protein kinase with NiRpn3 regulatory subunit of the 26S proteasome in Nicotiana tabacum. *Plant Journal* 33: 825–840.
- Legué V, Blancaflor E, Wymer C, Perbal G, Fantin D, Gilroy S. 1997. Cytoplasmic free Ca²⁺ in Arabidopsis roots changes in response to touch but not gravity. *Plant Physiology* 114: 789–800.
- Lemtiri-Chlieh F, MacRobbie EAC, Brearley CA. 2000. Inositol hexakisphosphate is a physiological signal regulating the K⁺-inward rectifying conductance in guard cells. *Proceedings of the National Academy of Sciences of the USA* 97: 8687–8692.
- Leung J, Merlot S, Giraudat J. 1997. The Arabidopsis ABCISIC ACID-INSENSITIVE2 (ABI2) and ABI1 genes encode homologous protein phosphatases 2C involved in abscisic acid signal transduction. *Plant Cell* 9: 759–771.
- Levine A, Pennell RI, Alvarez ME, Palmer R, Lamb C. 1996. Calcium-mediated apoptosis in a plant hypersensitive disease resistance response. *Current Biology* 6: 427–437.
- Lhuissier FGP, De Ruijter NCA, Sieberer BJ, Esseling JJ, Emons AMC. 2001. Time course of cell biological events evoked in legume root hairs by Rhizobium Nod factors: state of the art. *Annals of Botany* 87: 289–302.
- Li W-H, Llopsis J, Whitney M, Zlokarnik G, Tsien RY. 1998. Cell-permeant caged InsP₃ ester shows that Ca²⁺ spike frequency can optimize gene expression. *Nature* 392: 936–941.
- Liao B, Gawienowski MC, Zielinski RE. 1996. Differential stimulation of NAD kinase and binding of peptide substrates by wild-type and mutant plant calmodulin isoforms. *Archives of Biochemistry and Biophysics* 327: 53–60.
- Libert B, Franceschi VR. 1987. Oxalate in crop plants. *Journal of Agriculture and Food Chemistry* 35: 926–938.
- Ling V, Zielinski RE. 1993. Isolation of an Arabidopsis cDNA sequence encoding a 22 kDa calcium-binding protein (CaBP-22) related to calmodulin. *Plant Molecular Biology* 22: 207–214.
- Liu J, Zhu J-K. 1998. A calcium sensor homolog required for plant salt tolerance. *Science* 280: 1943–1945.
- Liu Z, Xia M, Poovaiah BW. 1998. Chimeric calcium/calmodulin-dependent protein kinase in tobacco: differential regulation by calmodulin isoforms. *Plant Molecular Biology* 38: 889–897.
- Luan S, Kudla J, Rodríguez-Concepción M, Yalovsky S, Gruissem W. 2002. Calmodulins and calcineurin B-like proteins: calcium sensors for specific signal response coupling in plants. *Plant Cell* 14: S389–S400.
- McAinsh MR, Hetherington AM. 1998. Encoding specificity in Ca²⁺ signalling systems. *Trends in Plant Science* 3: 32–36.
- McAinsh MR, Brownlee C, Hetherington AM. 1992. Visualizing changes in cytosolic-free Ca²⁺ during the response of stomatal guard cells to abscisic acid. *Plant Cell* 4: 1113–1122.
- McAinsh MR, Clayton H, Mansfield TA, Hetherington AM. 1996. Changes in stomatal behavior and guard cell cytosolic free calcium in response to oxidative stress. *Plant Physiology* 111: 1031–1042.
- McAinsh MR, Webb AAR, Taylor JE, Hetherington AM. 1995. Stimulus-induced oscillations in guard cell cytosolic free calcium. *Plant Cell* 7: 1207–1219.
- McLaughlin SB, Wimmer R. 1999. Calcium physiology and terrestrial ecosystem processes. *New Phytologist* 142: 373–417.
- Malhó R. 1998. Role of 1,4,5-inositol triphosphate-induced Ca²⁺ release in pollen tube orientation. *Sexual Plant Reproduction* 11: 231–235.
- Malhó R, Trewavas AJ. 1996. Localized apical increases of cytosolic free calcium control pollen tube orientation. *Plant Cell* 8: 1935–1949.
- Malhó R, Camacho L, Moutinho A. 2000. Signalling pathways in pollen tube growth and reorientation. *Annals of Botany* 85: 59–68.
- Malhó R, Moutinho A, van der Luit A, Trewavas AJ. 1998. Spatial characteristics of calcium signalling: the calcium wave as a basic unit in plant cell calcium signalling. *Philosophical Transactions of the Royal Society of London Series B* 353: 1463–1473.
- Marschner H. 1995. *Mineral nutrition of higher plants, 2nd edn.* London: Academic Press.
- Mäser P, Thomine S, Schroeder JI, Ward JM, Hirschi K, Sze H, Talke IN, Amtmann A, Maathuis FJM, Sanders D *et al.* 2001. Phylogenetic relationships within cation transporter families of Arabidopsis. *Plant Physiology* 126: 1646–1667.
- Mazars C, Thion L, Thuleau P, Graziana G, Knight MR, Moreau M,

- Ranjeva R. 1997. Organization of cytoskeleton controls the changes in cytosolic calcium of cold-shocked *Nicotiana plumbaginifolia* protoplasts. *Cell Calcium* 22: 413–420.
- Messerli MA, Créton R, Jaffe LF, Robinson KR. 2000. Periodic increases in elongation rate precede increases in cytosolic Ca^{2+} during pollen tube growth. *Developmental Biology* 222: 84–98.
- Michalak M, Mariani P, Opas M. 1998. Calreticulin, a multifunctional Ca^{2+} binding chaperone of the endoplasmic reticulum. *Biochemistry and Cell Biology* 76: 779–785.
- Miedema H, Bothwell JHF, Brownlee C, Davies JM. 2001. Calcium uptake by plant cells – channels and pumps acting in concert. *Trends in Plant Science* 6: 514–519.
- Mithöfer A, Ebel J, Bhagwat AA, Boller T, Neuhaus-Url G. 1999. Transgenic aequorin monitors cytosolic calcium transients in soybean cells challenged with β -glucan or chitin elicitors. *Planta* 207: 566–574.
- Monroy AF, Dhinsa RS. 1995. Low-temperature signal transduction: induction of cold acclimation-specific genes of alfalfa by calcium at 25 °C. *Plant Cell* 7: 321–331.
- Moore CA, Bowen HC, Scrase-Field S, Knight MR, White PJ. 2002. The deposition of suberin lamellae determines the magnitude of cytosolic Ca^{2+} elevations in root endodermal cells subjected to cooling. *Plant Journal* 30: 457–466.
- Muir SR, Sanders D. 1997. Inositol 1,4,5-trisphosphate-sensitive Ca^{2+} release across nonvacuolar membranes in cauliflower. *Plant Physiology* 114: 1511–1521.
- Murata Y, Pei ZM, Mori IC, Schroeder J. 2001. Abscisic acid activation of plasma membrane Ca^{2+} channels in guard cells requires cytosolic NADPH and is differentially disrupted upstream and downstream of reactive oxygen species production in *abi-1* and *abi-2* protein phosphatase 2C mutants. *Plant Cell* 13: 2513–2523.
- Navarro-Avino JP, Hentzen AE, Bennett AB. 1999. Alternative transcription initiation sites generate two *LCA1* Ca^{2+} -ATPase mRNA transcripts in tomato roots. *Plant Molecular Biology* 40: 133–140.
- Navazio L, Bewell MA, Siddiqua A, Dickinson GD, Galione A, Sanders D. 2000. Calcium release from the endoplasmic reticulum of higher plants elicited by the NADP metabolite nicotinic acid adenine dinucleotide phosphate. *Proceedings of the National Academy of Sciences of the USA* 97: 8693–8698.
- Navazio L, Mariani P, Sanders D. 2001. Mobilization of Ca^{2+} by cyclic ADP-ribose from the endoplasmic reticulum of cauliflower florets. *Plant Physiology* 125: 2129–2138.
- Ng CK-Y, Carr K, McAinsh MR, Powell B, Hetherington AM. 2001a. Drought-induced guard cell signal transduction involves sphingosine-1-phosphate. *Nature* 410: 596–598.
- Ng CK-Y, McAinsh MR, Gray JE, Hunt L, Leckie CP, Mills L, Hetherington AM. 2001b. Calcium-based signalling systems in guard cells. *New Phytologist* 151: 109–120.
- Nozawa A, Koizumi, Sano H. 2001. An Arabidopsis SNF1-related protein kinase, AtSR1, interacts with a calcium-binding protein, AtCBL2, of which transcripts respond to light. *Plant and Cell Physiology* 42: 976–981.
- Patharkar OR, Cushman JC. 2000. A stress-induced calcium-dependent protein kinase from *Mesembryanthemum crystallinum* phosphorylates a two-component pseudo-response regulator. *Plant Journal* 24: 679–691.
- Pauly N, Knight MR, Thuleau P, Graziana A, Muto S, Ranjeva R, Mazars C. 2001. The nucleus together with the cytosol generates patterns of specific cellular calcium signatures in tobacco suspension culture cells. *Cell Calcium* 30: 413–421.
- Pei Z-M, Murata Y, Benning G, Thomine S, Klüsener B, Allen GJ, Grill E, Schroeder JI. 2000. Calcium channels activated by hydrogen peroxide mediate abscisic acid signalling in guard cells. *Nature* 406: 731–734.
- Perera IY, Heilmann, Boss WF. 1999. Transient and sustained increases in inositol 1,4,5-trisphosphate precede the differential growth response in gravistimulated maize pulvini. *Proceedings of the National Academy of Sciences of the USA* 96: 5838–5843.
- Perfus-Barbeoch L, Leonhardt N, Vavasseur A, Forestier C. 2002. Heavy metal toxicity: cadmium permeates through calcium channels and disturbs the plant water status. *Plant Journal* 32: 539–548.
- Piao HL, Lim JH, Kim SJ, Cheong G-W, Hwang I. 2001. Constitutive over-expression of AtGSK1 induces NaCl stress responses in the absence of NaCl stress and results in enhanced NaCl tolerance in *Arabidopsis*. *Plant Journal* 27: 305–314.
- Pickard BG, Ding JP. 1993. The mechanosensory calcium-selective ion channel: key component of a plasmalemmal control centre? *Australian Journal of Plant Physiology* 20: 439–459.
- Pittman JK, Shigaki T, Cheng N-H, Hirschi KD. 2002a. Mechanism of N-terminal autoinhibition in the *Arabidopsis* $\text{Ca}^{2+}/\text{H}^{+}$ antiporter CAX1. *Journal of Biological Chemistry* 277: 26452–26459.
- Pittman JK, Sreevidya CS, Shigaki T, Ueoka-Nakanishi H, Hirschi KD. 2002b. Distinct N-terminal regulatory domains of $\text{Ca}^{2+}/\text{H}^{+}$ antiporters. *Plant Physiology* 130: 1054–1062.
- Plieth C. 2001. Plant calcium signaling and monitoring: pros and cons and recent experimental approaches. *Protoplasma* 218: 1–23.
- Plieth C, Trewavas AJ. 2002. Reorientation of seedlings in the earth's gravitational field induces cytosolic calcium transients. *Plant Physiology* 129: 786–796.
- Plieth C, Hansen U-P, Knight H, Knight MR. 1999. Temperature sensing by plants: the primary characteristics of signal perception and calcium response. *Plant Journal* 18: 491–497.
- Pottosin II, Dobrovinskaya OR, Muñiz J. 2001. Conduction of monovalent and divalent cations in the slow vacuolar channel. *Journal of Membrane Biology* 181: 55–65.
- Pottosin II, Tikhonova LI, Hedrich R, Schönknecht G. 1997. Slowly activating vacuolar channels cannot mediate Ca^{2+} -induced Ca^{2+} -release. *Plant Journal* 12: 1387–1398.
- Price AH, Taylor A, Ripley SJ, Griffiths A, Trewavas AJ, Knight MR. 1994. Oxidative signals in tobacco increase cytosolic calcium. *Plant Cell* 6: 1301–1310.
- Prychid CJ, Rudall PJ. 1999. Calcium oxalate crystals in monocotyledons: a review of their structure and systematics. *Annals of Botany* 84: 725–739.
- Reddy ASN. 2001. Calcium: silver bullet in signaling. *Plant Science* 160: 381–404.
- Reddy ASN, Reddy VS, Golovkin M. 2000. A calmodulin binding protein from *Arabidopsis* is induced by ethylene and contains a DNA-binding motif. *Biochemical and Biophysical Research Communications* 279: 762–769.
- Reddy VS, Ali GS, Reddy ASN. 2002. Genes encoding calmodulin-binding proteins in the *Arabidopsis* genome. *Journal of Biological Chemistry* 277: 9840–9852.
- Reddy VS, Safadi F, Zielinski RE, Reddy ASN. 1999. Interaction of a kinesin-like protein with calmodulin isoforms from *Arabidopsis*. *Journal of Biological Chemistry* 274: 31727–31733.
- Ritchie SM, Swanson SJ, Gilroy S. 2002. From common signalling components to cell specific responses: insights from the cereal aleurone. *Physiologia Plantarum* 115: 342–351.
- Roberts SK, Snowman BN. 2000. The effects of ABA on channel-mediated K^{+} transport across higher plant roots. *Journal of Experimental Botany* 51: 1585–1594.
- Rodríguez-Concepción M, Yalovsky S, Zik M, Fromm H, Gruissem W. 1999. The prenylation status of a novel plant calmodulin directs plasma membrane or nuclear localization of the protein. *EMBO Journal* 18: 1996–2007.
- Romeis T, Ludwig AA, Martin R, Jones JDG. 2001. Calcium-dependent protein kinases play an essential role in a plant defence response. *EMBO Journal* 20: 5556–5567.
- Rudd JJ, Franklin-Tong VE. 2001. Unravelling response-specificity in Ca^{2+} signalling pathways in plant cells. *New Phytologist* 151: 7–33.
- Saijo Y, Hata S, Kyozuka J, Shimamoto K, Izui K. 2000. Over-expression of a single Ca^{2+} -dependent protein kinase confers both cold and salt/drought tolerance on rice plants. *Plant Journal* 23: 319–327.
- Sanders D, Brownlee C, Harper JF. 1999. Communicating with calcium. *Plant Cell* 11: 691–706.
- Sanders D, Pelloux J, Brownlee C, Harper JF. 2002. Calcium at the crossroads of signaling. *Plant Cell* 14: S401–S417.
- Sattelmacher B. 2001. The apoplast and its significance for plant mineral nutrition. *New Phytologist* 149: 167–192.
- Schonknecht G, Spormaker P, Steinmeyer R, Bruggeman L, Ache P, Dutta R, Reintanz B, Godde M, Hedrich R, Palme K. 2002. KCO1 is a component of the slow-vacuolar SV ion channel. *FEBS Letters* 511: 28–32.

- Schroeder JI, Allen GJ, Hugouvieux V, Kwak JM, Waner D. 2001. Guard cell signal transduction. *Annual Review of Plant Physiology and Plant Molecular Biology* 52: 627–658.
- Sedbrook JC, Kronebusch PJ, Borisy GG, Trewavas AJ, Masson PH. 1996. Transgenic *AEQUORIN* reveals organ-specific cytosolic Ca²⁺ responses to anoxia in *Arabidopsis thaliana* seedlings. *Plant Physiology* 111: 243–257.
- Shacklock PS, Read ND, Trewavas AJ. 1992. Cytosolic free calcium mediates red light-induced photomorphogenesis. *Nature* 358: 753–755.
- Shaw SL, Long SR. 2003. Nod factor elicits two separable calcium responses in *Medicago truncatula* root hair cells. *Plant Physiology* 131: 976–984.
- Shear CB. 1975. Calcium-related disorders of fruits and vegetables. *HortScience* 10: 361–365.
- Sheen J. 1996. Ca²⁺-dependent protein kinases and stress signal transduction in plants. *Science* 274: 1900–1902.
- Shi J, Kim K-N, Ritz O, Albrecht V, Gupta R, Harter K, Luan S, Kudla J. 1999. Novel protein kinases associated with calcineurin B-like calcium sensors in Arabidopsis. *Plant Cell* 11: 2393–2405.
- Shigaki T, Hirschi K. 2000. Characterisation of CAX-like genes in plants: implications for functional diversity. *Gene* 257: 291–298.
- Shigaki T, Sreevidya C, Hirschi KD. 2002. Analysis of the Ca²⁺ domain in the *Arabidopsis* H⁺/Ca²⁺ antiporters CAX1 and CAX3. *Plant Molecular Biology* 50: 475–483.
- Smith RL, Wallace A. 1956. Cation-exchange capacity of roots and its relation to calcium and potassium content of plants. *Soil Science* 81: 97–109.
- Snaydon RW, Bradshaw AD. 1969. Differences between natural populations of *Trifolium repens* L. in response to mineral nutrients. *Journal of Applied Ecology* 6: 185–202.
- Snedden WA, Fromm H. 2001. Calmodulin as a versatile calcium signal transducer in plants. *New Phytologist* 151: 35–66.
- Staxén I, Pical C, Montgomery LT, Gray JE, Hetherington AM, McAinsh MR. 1999. Abscisic acid induces oscillations in guard-cell cytosolic free calcium that involve phosphoinositide-specific phospholipase C. *Proceedings of the National Academy of Sciences of the USA* 96: 1779–1784.
- Stoelzle S, Kagawa T, Wada M, Hedrich R, Dietrich P. 2003. Blue light activates calcium-permeable channels in *Arabidopsis* mesophyll cells via the phototropin signaling pathway. *Proceedings of the National Academy of Sciences of the USA* 100: 1456–1461.
- Straatman KR, Dove SK, Holdaway-Clarke T, Hepler PK, Kunkel JG, Franklin-Tong VE. 2001. Calcium signalling in pollen of *Papaver rhoeas* undergoing the self-incompatibility SI response. *Sexual Plant Reproduction* 14: 105–110.
- Strynadka NCJ, James MNG. 1989. Crystal structures of the helix–loop–helix calcium-binding proteins. *Annual Review of Biochemistry* 58: 951–998.
- Subbaiah CC, Bush DS, Sachs MM. 1994. Elevation of cytosolic calcium precedes anoxic gene expression in maize suspension-cultured cells. *Plant Cell* 6: 1747–1762.
- Subbaiah CC, Bush DS, Sachs MM. 1998. Mitochondrial contribution to the anoxic Ca²⁺ signal in maize suspension-cultured cells. *Plant Physiology* 118: 759–771.
- Sze H, Liang F, Hwang I, Curran AC, Harper JF. 2000. Diversity and regulation of plant Ca²⁺ pumps: insights from expression in yeast. *Annual Review of Plant Physiology and Plant Molecular Biology* 51: 433–462.
- Szymanski DB, Liao B, Zielinski RE. 1996. Calmodulin isoforms differentially enhance the binding of cauliflower nuclear proteins and recombinant TGA3 to a region derived from the Arabidopsis *Cam-3* promoter. *Plant Cell* 8: 1069–1077.
- Tähtiharju S, Sangwan V, Monroy AF, Dhindsa RS, Borg M. 1997. The induction of *kin* genes in cold-acclimating *Arabidopsis thaliana*. Evidence of a role for calcium. *Planta* 203: 442–447.
- Takahashi K, Isobe M, Knight MR, Trewavas AJ, Muto S. 1997. Hypoosmotic shock induces increases in cytosolic Ca²⁺ in tobacco suspension-culture cells. *Plant Physiology* 113: 587–594.
- Takezawa D, Liu ZH, An G, Poovaiyah BW. 1995. Calmodulin gene family in potato: developmental and touch-induced expression of the mRNA encoding a novel isoform. *Plant Molecular Biology* 27: 693–703.
- Thion L, Mazars C, Nacry P, Bouchez D, Moreau M, Ranjeva R, Thuleau P. 1998. Plasma membrane depolarization-activated calcium channels, stimulated by microtubule-depolymerizing drugs in wild-type *Arabidopsis thaliana* protoplasts, display constitutively large activities and a longer half-life in *ton2* mutant cells affected in the organization of cortical microtubules. *Plant Journal* 13: 603–610.
- Thion L, Mazars C, Thuleau P, Graziana A, Rossignol M, Moreau M, Ranjeva R. 1996. Activation of plasma-membrane voltage-dependent calcium-permeable channels by disruption of microtubules in carrot cells. *FEBS Letters* 393: 13–18.
- Thompson K, Parkinson JA, Band SR, Spencer RE. 1997. A comparative study of leaf nutrient concentrations in a regional herbaceous flora. *New Phytologist* 136: 679–689.
- Torres MA, Onouchi H, Hamada S, Machida C, Hammond-Kosack KE, Jones JDG. 1998. Six *Arabidopsis thaliana* homologues of the human respiratory burst oxidase (gp91^{phox}). *Plant Journal* 14: 365–370.
- Townley HE, Knight MR. 2002. Calmodulin as a potential negative regulator of Arabidopsis COR gene expression. *Plant Physiology* 128: 1169–1172.
- Trewavas A. 1999. Le calcium, c'est la vie: calcium makes waves. *Plant Physiology* 120: 1–6.
- Urao T, Katagiri T, Mizoguchi T, Yamaguchi-Shinozaki K, Hayashida N, Shinozaki K. 1994. Two genes that encode Ca²⁺-dependent protein kinases are induced by drought and high-salt stresses in *Arabidopsis thaliana*. *Molecular and General Genetics* 244: 331–340.
- van den Wijngaard PWJ, Bunney TD, Roobeek I, Schonknecht G, de Boer AH. 2001. Slow vacuolar channels from barley mesophyll cells are regulated by 14-3-3 proteins. *FEBS Letters* 488: 100–104.
- van der Luit AH, Olivari C, Haley A, Knight MR, Trewavas AJ. 1999. Distinct calcium signaling pathways regulate calmodulin gene expression in tobacco. *Plant Physiology* 121: 705–714.
- Verma PK, Upadhyaya KC. 1998. A multiplex RT-PCR assay for analysis of relative transcript levels of different members of multigene families: application to *Arabidopsis* calmodulin gene family. *Biochemistry and Molecular Biology International* 46: 699–706.
- Véry A-A, Davies JM. 2000. Hyperpolarization-activated calcium channels at the tip of Arabidopsis root hairs. *Proceedings of the National Academy of Sciences of the USA* 97: 9801–9806.
- Véry A-A, Sentenac H. 2002. Cation channels in the Arabidopsis plasma membrane. *Trends in Plant Science* 7: 168–175.
- Wacquant J.-P. 1977. Physicochemical selectivity for cations and CEC of grass roots. *Plant and Soil* 47: 257–261.
- Wais RJ, Galera C, Oldroyd G, Catoira R, Penmettsa RV, Cook D, Gough C, Dénarie J, Long SR. 2000. Genetic analysis of calcium spiking responses in nodulation mutants of *Medicago truncatula*. *Proceedings of the National Academy of Sciences of the USA* 97: 13407–13412.
- Walker SA, Viprey V, Downie JA. 2000. Dissection of nodulation signaling using pea mutants defective for calcium spiking induced by Nod factors and chitin oligomers. *Proceedings of the National Academy of Sciences of the USA* 97: 13413–13418.
- Wang X. 2001. Plant phospholipases. *Annual Review of Plant Physiology and Plant Molecular Biology* 52: 211–231.
- Webb AAR, Larman MG, Montgomery LT, Taylor JE, Hetherington AM. 2001. The role of calcium in ABA-induced gene expression and stomatal movements. *Plant Journal* 26: 351–362.
- Webb AAR, McAinsh MR, Mansfield TA, Hetherington AM. 1996. Carbon dioxide induces increases in guard cell cytosolic free calcium. *Plant Journal* 9: 297–304.
- White PJ. 1997. Cation channels in the plasma membrane of rye roots. *Journal of Experimental Botany* 48: 499–514.
- White PJ. 1998. Calcium channels in the plasma membrane of root cells. *Annals of Botany* 81: 173–183.
- White PJ. 2000. Calcium channels in higher plants. *Biochimica et Biophysica Acta* 1465: 171–189.
- White PJ. 2001. The pathways of calcium movement to the xylem. *Journal of Experimental Botany* 52: 891–899.
- White PJ, Davenport RJ. 2002. The voltage-independent cation channel in the plasma membrane of wheat roots is permeable to divalent

- cations and may be involved in cytosolic Ca^{2+} homeostasis. *Plant Physiology* **130**: 1386–1395.
- White PJ, Banfield J, Diaz M. 1992.** Unidirectional Ca^{2+} fluxes in roots of rye (*Secale cereale* L.). A comparison of excised roots with roots of intact plants. *Journal of Experimental Botany* **43**: 1061–1074.
- White PJ, Bowen HC, Demidchik V, Nichols C, Davies JM. 2002a.** Genes for calcium-permeable channels in the plasma membrane of plant root cells. *Biochimica et Biophysica Acta* **1564**: 299–309.
- White PJ, Whiting SN, Baker AJM, Broadley MR. 2002b.** Does zinc move apoplastically to the xylem in roots of *Thlaspi caerulescens*? *New Phytologist* **153**: 199–211.
- Wood NT, Haley A, Viry-Moussaid, Johnson CH, van der Luit AH, Trewavas AJ. 2001.** The calcium rhythms of different cell types oscillate with different circadian phases. *Plant Physiology* **125**: 787–796.
- Wu CC, Kuo-Huang LL. 1997.** Calcium crystals in the leaves of some species of Moraceae. *Botanical Bulletin of Academia Sinica* **38**: 97–104.
- Wu Y, Kuzma J, Maréchal E, Graeff R, Lee HC, Foster R, Chua NH. 1997.** Abscisic acid signaling through plant cyclic ADP-ribose in plants. *Science* **278**: 2126–2130.
- Wu Z, Liang F, Hong B, Young JC, Sussman MR, Harper JF, Sze H. 2002.** An endoplasmic reticulum-bound $\text{Ca}^{2+}/\text{Mn}^{2+}$ pump, ECA1, supports plant growth and confers tolerance to Mn^{2+} stress. *Plant Physiology* **130**: 128–137.
- Wymer CL, Bibikova TN, Gilroy S. 1997.** Cytoplasmic free calcium distributions during the development of root hairs of *Arabidopsis thaliana*. *Plant Journal* **12**: 427–439.
- Xiong L, Schumaker KS, Zhu J-K. 2002.** Cell signaling during cold, drought, and salt stress. *Plant Cell* **14**: S165–S183.
- Yamakawa H, Mitsuhashi I, Ito N, Seo S, Kamada H, Ohashi Y. 2001.** Transcriptionally and post-transcriptionally regulated response of 13 calmodulin genes to tobacco mosaic virus-induced cell death and wounding in tobacco plants. *European Journal of Biochemistry* **268**: 3916–3929.
- Yang T, Poovaiah BW. 2000.** An early ethylene up-regulated gene encoding a calmodulin-binding protein involved in plant senescence and death. *Journal of Biological Chemistry* **275**: 38467–38473.
- Yang T, Lev-Yadun S, Feldman M, Fromm H. 1998.** Developmentally regulated organ-, tissue-, and cell-specific expression of calmodulin genes in common wheat. *Plant Molecular Biology* **37**: 109–120.
- Yoon GM, Cho HS, Ha HJ, Liu JR, Lee HP. 1999.** Characterization of *NtCDPK1*, a calcium-dependent protein kinase gene in *Nicotiana tabacum*, and the activity of its encoded protein. *Plant Molecular Biology* **39**: 991–1001.
- Zhang L, Lu Y-T. 2003.** Calmodulin-binding protein kinases in plants. *Trends in Plant Science* **8**: 123–127.
- Zhang W-H, Rengel Z. 1999.** Aluminium induces an increase in cytoplasmic calcium in intact wheat root apical cells. *Australian Journal of Plant Physiology* **26**: 401–409.
- Zielinski RE. 1998.** Calmodulin and calmodulin-binding proteins in plants. *Annual Review of Plant Physiology and Plant Molecular Biology* **49**: 697–725.
- Zielinski RE. 2002.** Characterization of three new members of the *Arabidopsis thaliana* calmodulin gene family: conserved and highly diverged members of the gene family functionally complement a yeast calmodulin null. *Planta* **214**: 446–455.